



- NR16N3
- NR20N3
- NR16N3H
- NR20N3H
- NR25N3H
- NR20N3HX

PERFECTLY FITTED TO DRIVE PROFIT

SPECIFICATIONS
REACH TRUCKS 48V, 1.6 - 2.5 TONNES



EQUIPPED FOR SUSTAINED PRODUCTIVITY

CAT® LIFT TRUCKS EXPANDS CHOICE IN ITS COMPREHENSIVE REACH TRUCK RANGE BY ADDING SIX NR-N3 STANDARD AND HEAVY DUTY MODELS. ERGONOMICALLY AND COMFORTABLY EQUIPPED FOR LONG HOURS IN THE DRIVING SEAT, THEY MAXIMISE YOUR PROFITS WITH HIGH THROUGHPUT AND LOW DOWNTIME EXPENSE.



For a comfortable, tailored fit, the truck's armrests and even its floor height are adjustable. *Palm Steering* and a multifunctional joystick allow relaxed but precise operation, while a tilting seat reduces strain when viewing loads at height.



Fast but smooth and safe action is assured by automatic drive and hydraulic motion speed controls which adapt to steering angle and lifting height. The Mast Tilt Control (MTC) damping system – minimising delays and improving stability – is standard or optional depending on mast choice.



To minimise downtime and maintenance costs, the trucks are robustly constructed, fitted with a user-friendly display and onboard diagnostics, and designed for quick service access. Total cost of operation can be reduced even further with the high-efficiency, long-life, virtually maintenance-free Li-ion battery option.



Along with standard duty models, choices include high-performance trucks for heavier duties and an 'X' model for heavy and extra high lifting – up to 12.1 metres. Each can be matched perfectly to its application thanks to a long list of options.

LOWER COST OF OWNERSHIP

- Robust construction minimises damage and wear, even in demanding multi-shift operations.
- Heavy duty drive wheel is highly durable and easy to maintain, with a larger diameter, extra width and unique tread design which increase grip and stability as well as lifetime.
- User-friendly display and onboard diagnostics encourage correct use of truck and speed up maintenance.
- PIN code identification and programmability prevent unauthorised use and allow matching of truck performance settings to driver experience and application.
- Easy battery access enables driver to make quick checks without leaving the truck.
- Fast service access to systems and components reduces downtime.
- Li-ion battery option adds even greater efficiency and runtime, along with minimal maintenance needs and much longer life, for lower long-term total cost of operation (TCO).

UNMATCHED PRODUCTIVITY

- Automatic drive speed reduction makes smooth adjustments according to steering angle and fork height to maintain stability, safety and confidence when cornering or carrying raised loads.
- Automatic hydraulic motion control optimises lift, lower, reach, tilt and side shift speeds according to lift height and keeps all movements smooth, quiet and precise.
- Mast Tilt Control (MTC) damping system reduces oscillations by up to 80%, allowing faster and more stable load handling. (Standard on tilting masts with lift heights above 7.25 m. Optional for other tilting masts.)
- Tilting mast reduces aisle width necessary and enhances safety of handling in lifts up to 10 m. (Not available on NR20N3HX, which has fork tilt instead.)
- 360-degree steering option enables fluid turning without stopping to change direction.
- Fast travel and lift speeds come as standard.
- High-performance option increases top speed from 12.5 to 14.5 km/h. (Not available on NR25N3H or NR20N3HX.)
- Motor-powered battery bed option enables exchanges in just one minute, for 24/7 productivity.
- Li-ion option enhances performance and permits fast opportunity charging for continuous operation without battery changes.

SAFETY AND ERGONOMICS

- *Palm Steering* on adjustable floating armrest offers relaxed driving position and operation with minimal movement, effort or strain – ideal if driver is seated for long periods.
- Multifunctional joystick with adjustable armrest fits hand perfectly, positions all hydraulic controls optimally, minimises effort and enables precise individual and simultaneous actions.
- Optional fingertip hydraulic controls with adjustable armrest ensure ergonomically perfect hand positioning, anatomical support and free movement.
- Electrically adjustable floor height combines with adjustment of armrests and seat to give the perfect fit for each driver.
- Tilting seat tips back by 18 degrees, to reduce strain when viewing and handling loads at height, and is adapted to the driver's weight.
- Tapered seat backrest enables easier turning of body – with less strain – toward driving direction.
- Spacious driver's compartment with high roof safely and comfortably accommodates users of all sizes.
- Excellent all-round view is enabled by design of mast, fork carriage, overhead bars, pillars and chassis, and by use of dark, non-reflective paint.
- Transparent overhead guard roof option gives unobstructed view of forks and load when handling at height and protects driver from both small and large falling objects.
- Intuitive display keeps drivers fully informed and is optimally positioned and angled for clear viewing.
- Direction control is switched using accelerator pedal, leaving right hand free to concentrate on hydraulic functions.
- Automotive pedal layout is intuitive to car drivers, while 'dead man' safety switch is effortlessly activated by the weight of the left foot.
- Smooth entry and exit are aided by ergonomic grab handles and low intermediate step with non-slip surface.
- Standard safety features include operator presence switch, mast lock system and automatic parking brake.

STANDARD EQUIPMENT AND OPTIONS

	NR16N3	NR16N3H	NR20N3	NR20N3H	NR25N3H	NR20N3HX
GENERAL						
Automatic electric parking brake	●	●	●	●	●	●
Steering wheel angle indicator	●	●	●	●	●	●
Battery indicator with cut-out at 20% remaining battery level	●	●	●	●	●	●
ATC 3 truck computer with display and keyboard	●	●	●	●	●	●
Integrated side shift DTFV mast	●	●	●	●	●	●
Electrically adjustable floor height	●	●	●	●	●	●
Suspension seat with weight-controlled tilting high backrest	●	●	●	●	●	●
Increased drive speed 14,5 km/h	○	○	○	○	–	–
Chill store design, down to +1° C	●	●	●	●	●	●
Paper storage and cup holder	●	●	●	●	●	●
Battery reach-out	●	●	●	●	●	●
Battery on rollers	○	○	○	○	○	○
Motor power battery bed	○	○	○	○	○	○
Other RAL colour	○	○	○	○	○	○
POWER SOURCE						
Li-ion battery* **	○	○	○	○	○	–
Lead-acid battery	○	○	○	○	○	○
Battery cover plate	○	○	○	○	○	○
MAST, FORKS AND CARRIAGE						
Tilting mast	●	●	●	●	●	–
Fork tilt	○	○	○	○	○	●
Integral fork positioner/side shift DTFV mast	○	○	○	○	○	–
Load backrest	○	○	○	○	○	○
Load backrest in combination with fork positioner/side shift	○	○	○	○	○	–
Mast Tilt Control (MTC) damping system on tilting masts (std with lift heights >7.2 m, option for <7.2 m)	●	●	●	●	●	–
Lift stop with/without restart	○	○	○	○	○	○
Lift height indicator (std with load-weight-adjusted control option)	○	○	○	○	○	○
Level selector	○	○	○	○	○	○
Level assistance system, LAS	○	○	○	○	○	○
Load weight indicator (std with load-weight-adjusted control option)	○	○	○	○	○	○
Fork camera with RLED display	○	○	○	○	○	○
Horizontal forks	○	○	○	○	○	○
Central position of side shift	○	○	○	○	○	○
Automatic hydraulic motion control	●	●	●	●	●	●



FULL LI-ION* BATTERY INTEGRATION

Full integration of Li-ion battery communication on Cat reach trucks enables all battery-related information to be presented clearly via the truck's inbuilt full-colour display.

* Li-ion battery option is available in selected regions

** Not in combination with cold store design, 0°C to -35°C

STANDARD EQUIPMENT AND OPTIONS

	NR16N3	NR16N3H	NR20N3	NR20N3H	NR25N3H	NR20N3HX
DRIVE AND LIFT CONTROLS						
Electric-powered <i>Palm Steering</i> unit on floating armrest	●	●	●	●	●	●
180-degree steering	●	●	●	●	●	●
360-degree steering	○	○	○	○	○	○
Active Spin Reduction	○	○	○	○	○	○
Automatic drive speed reduction	●	●	●	●	●	●
Hands-free direction control, HFDC, via accelerator pedal	●	●	●	●	●	●
Hand-operated direction control	○	○	○	○	○	○
Multifunctional joystick	●	●	●	●	●	●
Fingertip hydraulic control	○	○	○	○	○	○
Midi steering wheel	○	○	○	○	○	○
Key switch entry	○	○	○	○	○	○
Creep speed at preset level 500 mm	○	○	○	○	○	○
Creep speed at other levels	○	○	○	○	○	○
Impact sensors with display warning and horn	○	○	○	○	○	○
Impact sensors with display warning, horn and warning light on overhead guard	○	○	○	○	○	○
Load-weight-adjusted functioning of automatic drive speed and hydraulic motion controls	○	○	○	○	○	○
ELECTRIC						
Blue/red point safety light, towards driving direction	○	○	○	○	○	○
Automatic logoff	○	○	○	○	○	○
Working lights LED	○	○	○	○	○	○
Working lights LED for cabin	○	○	○	○	○	○
Warning light on the roof	○	○	○	○	○	○
Warning light for heated cabin	○	○	○	○	○	○
12V connector	○	○	○	○	○	○
Converter 48 - 12 V	○	○	○	○	○	○
Radio with MP3	○	○	○	○	○	○
Service alarm	○	○	○	○	○	○
OHG AND CABIN						
Heated cabin**	○	○	○	○	○	○
Window opening in cabin door	○	○	○	○	○	○
2-way intercom for cold store cabin	○	○	○	○	○	○
Transparent overhead guard roof	○	○	○	○	○	○
Mesh metal on overhead guard	○	○	○	○	○	○
Heated seat – fabric	○	○	○	○	○	○
Heated seat – PVC	○	○	○	○	○	○
Headrest for seat	○	○	○	○	○	○
Rear view mirror	○	○	○	○	○	○
Writing desk	○	○	○	○	○	○
Equipment holder, RAM system size C	○	○	○	○	○	○
Equipment holder, RAM system size C, 2 pcs	○	○	○	○	○	○
Equipment holder, RAM system size D	○	○	○	○	○	○
WHEEL OPTIONS						
Vulkollan® traction wheel 93 Shore	●	●	●	●	—	●
Vulkollan® traction wheel 95 Shore	○	○	○	○	●	○
Tractothan® traction wheel 93 Shore	○	○	○	○	○	○
Load wheel Ø 230mm	●	○	○	○	—	—
Load wheel Ø 285mm	—	●	●	●	●	●
Load wheel brakes, incl. Ø 285mm load wheel	—	○	○	○	●	○
Load wheel covers	○	○	○	○	○	○
ENVIRONMENT						
Cold store design, 0°C to -35°C **	○	○	○	○	○	○



Multifunctional joystick.



Optional Midi steering wheel.



Optional transparent overhead guard roof.



Optional writing desk.

* Li-ion battery option is available in selected regions
 ** Not in combination with cold store design, 0°C to -35°C

● Standard ○ Option

- Ast = Working aisle width
- Ast = $Wa + \sqrt{(l6 - x)^2 + (b12 / 2)^2} + a$
- Wa = Turning radius
- l6 = Pallet length (1200 mm)
- x = Load wheel axle to fork face
- b12 = Pallet width (800 or 1200 mm)
- a = Safety clearance = 2 x 100 mm

Characteristics		
1.1	Manufacturer	
1.2	Manufacturer's model designation	
1.3	Power source	
1.4	Operator type	
1.5	Load capacity	Q (kg)
1.6	Load centre distance	c (mm)
1.8	Load wheel axle to fork face (forks lowered)	x (mm)
1.9	Wheelbase	y (mm)
Weight		
2.1b	Truck weight without load, with maximum battery weight	kg
2.3	Axle loadings without load & with maximum battery weight, drive / load side	kg
2.4	Axle loading, mast forward, with nominal load, drive / load side	kg
2.5	Axle loading, mast retracted, with nominal load, drive / load side	kg
Wheels, Drive Train		
3.1	Tyres: PT = Power Thane, Vul = Vulkollan, P = Polyurethane, N = Nylon, R = Rubber drive / load side	
3.2	Tyre dimensions, drive side	Ø (mm)
3.3	Tyre dimensions, load side	Ø (mm)
3.5	Number of wheels, load / drive side (x = driven)	
3.7	Track width (centre of tyres), load side	b11 (mm)
Dimensions		
4.1	Fork tilt, forwards / backwards	∂/β °
4.2a	Height with mast lowered	h1 (mm)
4.3	Free lift	h2 (mm)
4.4	Lift height	h3 (mm)
4.5	Height with mast extended	h4 (mm)
4.7	Height to top of overhead guard	h6 (mm)
4.8	Seat or stand height	h7 (mm)
4.10	Height of support legs	h8 (mm)
4.15	Fork height, fully lowered	h13 (mm)
4.19	Overall length	l1 (mm)
4.20	Length to fork face	l2 (mm)
4.21	Overall width	b1/b2 (mm)
4.22	Fork dimensions (thickness, width, length)	s / e / l (mm)
4.23	Fork carriage to DIN	
4.24	Fork carriage width	b3 (mm)
4.25	Outside width over forks (minimum / maximum)	b5 (mm)
4.26	Inner width of support legs	b4 (mm)
4.28	Mast reach	l4 (mm)
4.32	Ground clearance at centre of wheelbase, (forks lowered)	m2 (mm)
4.33a	Working aisle width (Ast) with 1000 x 1200 mm pallets, load crosswise	Ast (mm)
4.34a	Working aisle width (Ast) with 800 x 1200 mm pallets, load lengthwise	Ast (mm)
4.35	Turning radius	Wa (mm)
4.37	Truck length including support legs	l7 (mm)
Performance		
5.1	Travel speed, with /without load	km / h
5.2	Lifting speed, with /without load	m / s
5.3	Lowering speed, with /without load	m / s
5.5	Rated drawbar pull, with /without load	N
5.8	Maximum gradeability with /without load	%
5.9	Acceleration time (10 metres) with /without load	s
5.10	Service brakes (mechanical /hydraulic /electric /pneumatic)	
Electric motors		
6.1	Drive motor capacity (60 min. short duty)	kW
6.2	Lift motor output at 15% duty factor	kW
6.4	Battery voltage/capacity at 5-hour discharge	V / Ah
6.5	Battery weight	kg
6.6b	Energy consumption according to VDI 60 cycle	kWh / h
Miscellaneous		
8.1	Type of drive control	
10.1	Maximum operating pressure for attachments	bar
10.2	Oil flow for attachments	l / min
10.7	Level of noise at the ear level of the driver according to EN 12 053:2001 and EN ISO 4871 in work LpAZ	dB (A)

Cat Lift Trucks	Cat Lift Trucks	Cat Lift Trucks
NR16N3	NR16N3H	NR20N3
Battery	Battery	Battery
Sit-on	Sit-on	Sit-on
1600	1600	2000
600	600	600
See table	See table	See table
1448		1530
3590	4320	4140
2000 / 1190	2360 / 1760	2290 / 1450
650 / 4140	1040 / 4680	550 / 5190
1750 / 3040	1900 / 3820	2040 / 3700
Vul	Vul	Vul
355 x 155	355 x 155	355 x 155
285 x 105	285 x 105	285 x 105
2 / 1 x	2 / 1 x	2 / 1 x
1128	1128 / 1255	1128 / 1255
1 / 4	1 / 4	1 / 4
See table	See table	See table
See table	See table	See table
See table	See table	See table
See table	See table	See table
2205	2205	2205
1.153 ¹⁾	1.153 ¹⁾	1.153 ¹⁾
235	235	235
See table	See table	See table
65	65	65
See table	See table	See table
See table	See table	See table
1270	1270 / 1397	1270 / 1397
40 / 100 / 1150	40 / 100 / 1150	42 / 100 / 1150
FEM 2A	FEM 2A	FEM 2A
830	830	830
316 - 697	316 - 697	316 - 697
912	903 / 1030	903 / 1030
See table	See table	See table
See table	See table	See table
See table	See table	See table
See table	See table	See table
See table	See table	See table
1800	1800	1910
14.3 / 14.5	14.3 / 14.5	14.3 / 14.5
0.49 / 0.80	0.48 / 0.68	0.37 / 0.63
0.49 / 0.48	0.5 / 0.48	0.55 / 0.43
0.2 / 0.2	0.2 / 0.2	0.2 / 0.2
14.9 / 19.6	11 / 15.2	11 / 16.5
4.8 / 4.4	5.1 / 4.6	4.8 / 4.4
Electric	Electric	Electric
7.2	7.2	7.2
15	15	15
48 - 465 / 620 / 775	48 - 620 / 775	48 - 620 / 775 / 930
712 / 892 / 1063	892 / 1063	892 / 1063 / 1240
5.3	5.3	5.3
Stepless	Stepless	Stepless
150	150	150
25	25	25
60.8	60.8	60.8

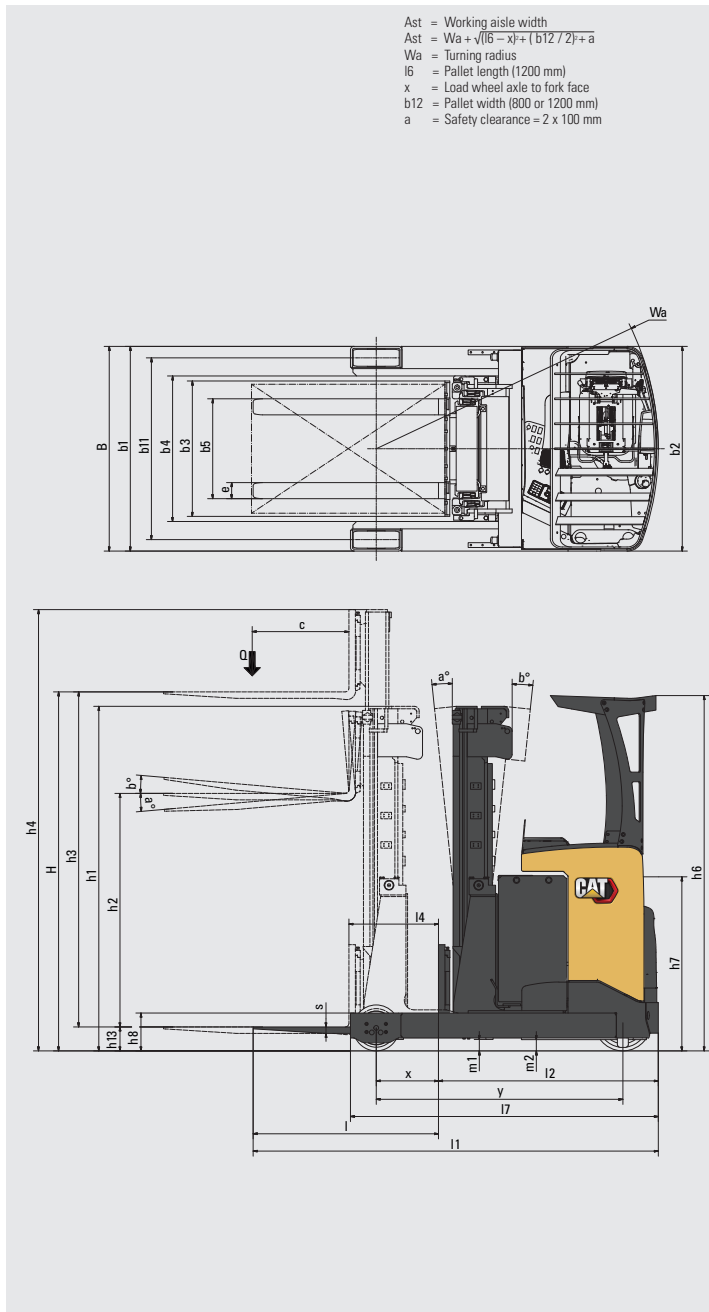

1) Measured with standard seat to SIP point

Characteristics				Cat Lift Trucks	Cat Lift Trucks	Cat Lift Trucks
Characteristics				NR20N3H	NR20N3HX	NR25N3H
1.1	Manufacturer					
1.2	Manufacturer's model designation					
1.3	Power source			Battery	Battery	Battery
1.4	Operator type			Sit-on	Sit-on	Sit-on
1.5	Load capacity	Q	(kg)	2000	2000	2500
1.6	Load centre distance	c	(mm)	600	600	600
1.8	Load wheel axle to fork face (forks lowered)	x	(mm)	See table	See table	See table
1.9	Wheelbase	y	(mm)	1530	1530	1630
Weight						
2.1b	Truck weight without load, with maximum battery weight		kg	4550	5200	4600
2.3	Axle loadings without load & with maximum battery weight, drive / load side		kg	2400 / 1750	2790 / 2410	2400 / 2000
2.4	Axle loading, mast forward, with nominal load, drive / load side		kg	650 / 5500	1060 / 6140	800 / 6100
2.5	Axle loading, mast retracted, with nominal load, drive / load side		kg	2050 / 4100	2280 / 4920	2100 / 4100
Wheels, Drive Train						
3.1	Tyres: PT = Power Thane, Vul = Vulkollan, P = Polyurethane, N = Nylon, R = Rubber drive / load side			Vul	Vul	Vul
3.2	Tyre dimensions, drive side	Ø	(mm)	355 x 155	355 x 155	355 x 155
3.3	Tyre dimensions, load side	Ø	(mm)	285 x 105	285 x 105	285 x 105
3.5	Number of wheels, load / drive side (x = driven)			2 / 1 x	2 / 1 x	2 / 1 x
3.7	Track width (centre of tyres), load side	b11	(mm)	1128 / 1255	1255	1255
Dimensions						
4.1	Fork tilt, forwards / backwards	∂/β	°	1 / 4	1 / 4	1 / 4
4.2a	Height with mast lowered	h1	(mm)	See table	See table	See table
4.3	Free lift	h2	(mm)	See table	See table	See table
4.4	Lift height	h3	(mm)	See table	See table	See table
4.5	Height with mast extended	h4	(mm)	See table	See table	See table
4.7	Height to top of overhead guard	h6	(mm)	2205	2205	2205
4.8	Seat or stand height	h7	(mm)	1.153 ¹⁾	1.153 ¹⁾	1.153 ¹⁾
4.10	Height of support legs	h8	(mm)	235	235	235
4.15	Fork height, fully lowered	h13	(mm)	65	65	65
4.19	Overall length	l1	(mm)	See table	See table	See table
4.20	Length to fork face	l2	(mm)	See table	See table	See table
4.21	Overall width	b1/b2	(mm)	1270 / 1397		1397
4.22	Fork dimensions (thickness, width, length)	s / e / l	(mm)	401 / 100 / 1150	40 / 100 / 1150	45 / 100 / 1150
4.23	Fork carriage to DIN			FEM 2A	FEM 2A	FEM 2A
4.24	Fork carriage width	b3	(mm)	830	830	830
4.25	Outside width over forks (minimum / maximum)	b5	(mm)	316 - 697	316 - 697	316 - 697
4.26	Inner width of support legs	b4	(mm)	903 / 1030	1030	1030
4.28	Mast reach	l4	(mm)	See table	See table	See table
4.32	Ground clearance at centre of wheelbase, (forks lowered)	m2	(mm)	70	70	70
4.33a	Working aisle width (Ast) with 1000 x 1200 mm pallets, load crosswise	Ast	(mm)	See table	See table	See table
4.34a	Working aisle width (Ast) with 800 x 1200 mm pallets, load lengthwise	Ast	(mm)	See table	See table	See table
4.35	Turning radius	Wa	(mm)	See table	See table	See table
4.37	Truck length including support legs	l7	(mm)	1910		2010
Performance						
5.1	Travel speed, with /without load		km / h	14.3 / 14.5	12 / 12	12 / 12
5.2	Lifting speed, with /without load		m / s	0.37 / 0.63	0.36 / 0.52	0.33 / 0.52
5.3	Lowering speed, with /without load		m / s	0.55 / 0.43	0.54 / 0.45	0.55 / 0.43
5.5	Rated drawbar pull, with /without load		N	0.2 / 0.2	0.2 / 0.2	0.2 / 0.2
5.8	Maximum gradeability with /without load		%	6.3 / 9.4	6.1 / 8.4	9.2 / 14.7
5.9	Acceleration time (10 metres) with /without load		s	4.8 / 4.4	4.8 / 4.4	4.8 / 4.4
5.10	Service brakes (mechanical /hydraulic /electric /pneumatic)			Electric	Electric	Electric
Electric motors						
6.1	Drive motor capacity (60 min. short duty)		kW	7.2	7.2	7.2
6.2	Lift motor output at 15% duty factor		kW	15	15	15
6.4	Battery voltage/capacity at 5-hour discharge		V / Ah	48 - 620 / 775 / 930	48 - 775 / 930	48 - 775 / 930
6.5	Battery weight		kg	892 / 1063 / 1240	1063 / 1240	1063 / 1240
6.6b	Energy consumption according to VDI 60 cycle		kWh / h	5.3	5.3	5.3
Miscellaneous						
8.1	Type of drive control			Stepless	Stepless	Stepless
10.1	Maximum operating pressure for attachments		bar	150	150	150
10.2	Oil flow for attachments		l / min	25	25	25
10.7	Level of noise at the ear level of the driver according to EN 12 053:2001 and EN ISO 4871 in work LpAZ		dB (A)	60.8	60.8	60.8

Ast = Working aisle width
 Ast = $Wa + \sqrt{(l6 - x)^2 + (b12 / 2)^2} + a$
 Wa = Turning radius
 l6 = Pallet length (1200 mm)
 x = Load wheel axle to fork face
 b12 = Pallet width (800 or 1200 mm)
 a = Safety clearance = 2 x 100 mm

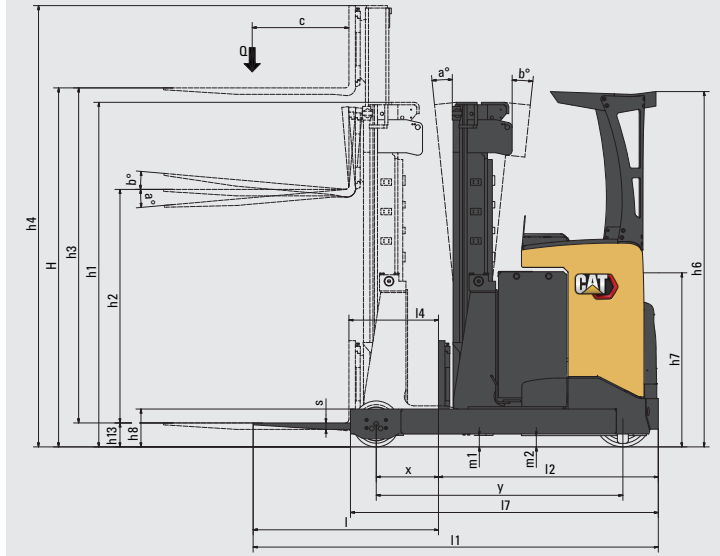
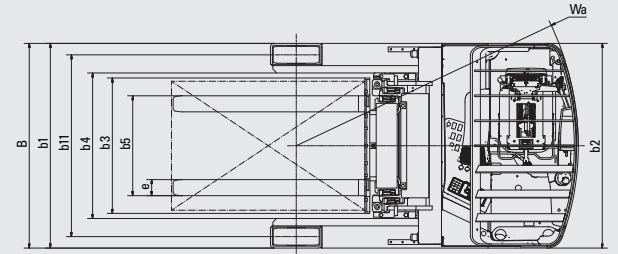

1) Measured with standard seat to SIP point

NR16N3 - NR20N3				
Mast Type	h3 + h13	h1	h2 + h13	h4
	mm	mm	mm	mm
DTFV	4800	2155	1615	5340
	5400	2355	1815	5940
	5700	2455	1915	6240
	6300	2655	2115	6840
	6750	2805	2265	7290
	7250	2972	2432	7790
	7950	3205	2665	8490
	8450	3372	2832	8990
	8950	3538	2998	9490

Mast Performance and Capacity

- h1 Lowered mast height
- h2 + h13 Free lift
- h3 + h13 Lift height
- h4 Raised mast height
- Q Lifting capacity, rated load
- c Load centre (distance)

NR16N3H				
Mast Type	h3 + h13	h1	h2 + h13	h4
	mm	mm	mm	mm
DTFV	6350	2972	2432	6890
	7050	3205	2665	7590
	7550	3372	2832	8090
	8050	3538	2998	8590
	8500	3688	3148	9040
	8950	3838	3298	9490
	9600	4055	3515	10140
	10200	4255	3715	10740
	10800	4455	3915	11340

NR20N3H				
Mast Type	h3 + h13	h1	h2 + h13	h4
	mm	mm	mm	mm
DTFV	6350	2972	2432	6890
	7050	3205	2665	7590
	7550	3372	2832	8090
	8050	3538	2998	8590
	8500	3688	3148	9040
	8950	3838	3298	9490
	9600	4055	3515	10140
	10200	4255	3715	10740
	10800	4455	3915	11340
		11500	4688	4148

NR25N3H				
Mast Type	h3 + h13	h1	h2 + h13	h4
	mm	mm	mm	mm
DTFV	4800	2455	1915	5340
	5850	2805	2265	6390
	6350	2972	2432	6890
	7050	3205	2665	7590
	7550	3372	2832	8090
	8050	3538	2998	8590
	8500	3688	3148	9040
		8950	3838	3298

NR20N3HX				
Mast Type	h3 + h13	h1	h2 + h13	h4
	mm	mm	mm	mm
DTFV	9600	4055	3515	10140
	10200	4255	3715	10740
	10800	4455	3915	11340
	11100	4555	4015	11640
	11600	4722	4182	12140
		12100	4888	4348

Model	Battery Capacity	Battery Weight	4.33a Ast	4.34a Ast	4.28 L4	4.20 L2	4.19 L1	1.8 x	4.35 Wa
	Ah	kg	mm	mm	mm	mm	mm	mm	mm
NR16N3	465	708	2689	2728	596	1229	2379	439	1668
	620	892	2740	2792	524	1301	2451	367	1668
	775	1063	2794	2857	490	1373	2535	295	1668
NR16N3H	620	892	2768	2832	418	1335	2485	306	1773
	775	1063	2824	2898	418	1407	2557	234	1773
NR20N3	620	892	2770	2808	625	1310	2460	551	1750
	775	1063	2821	2873	553	1382	2532	369	1750
	930	1240	2875	2938	481	1454	2604	297	1750
NR20N3H	620	892	2788	2831	600	1335	2485	416	1750
	775	1063	2839	2895	528	1407	2557	344	1750
	930	1240	2894	2961	456	1479	2629	272	1750
NR20N3HX	930	1240	2906	2976	430	1495	2645	256	1750
NR25N3H	775	1063	2877	2914	628	1412	2562	439	1850
	930	1240	2928	2978	556	1484	2634	367	1850

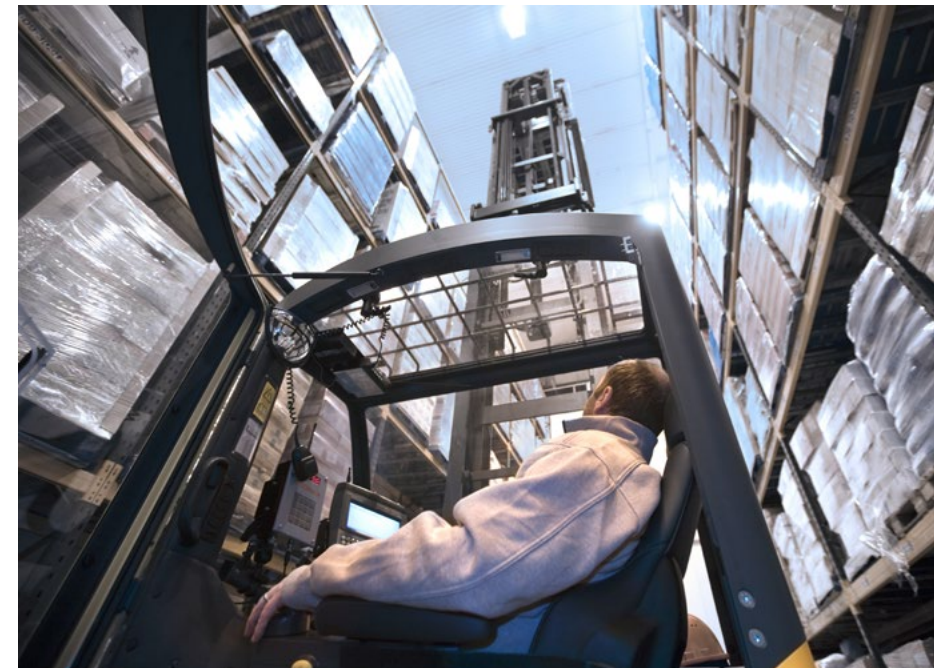

Optional cabin fitted with transparent overhead guard roof with protective mesh metal.

CAT® LI-ION BATTERIES

TIME TO SWITCH?



Lithium-ion (Li-ion) battery technology is now available as an option in almost all Cat® electric counterbalance and warehouse truck ranges. While lead-acid batteries remain a popular choice for our customers, and still have much to offer, they present various challenges which Li-ion can overcome.

Perhaps the most noticeable change when switching to Li-ion is the use of opportunity charging. Instead of exchanging batteries between shifts, you can simply plug into a fast charger during short breaks and keep the same battery going 24/7. This, together with other efficiency, environmental and safety benefits, makes Li-ion a very appealing alternative.



**LONGER
LIFE**



**HIGHER
EFFICIENCY**



**LONGER
RUNTIME**

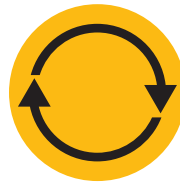

**CONSISTENT
PERFORMANCE**



**FASTER
CHARGING**



**NO BATTERY
CHANGING**



**NO DAILY
MAINTENANCE**



**INBUILT
PROTECTION**

Cat Li-ion advantages over lead-acid

Switching to Li-ion requires a higher initial investment, but this should be viewed against Li-ion's ongoing savings on energy, equipment, labour and downtime.

- **Longer life** – 3 to 4 times lead-acid lifespan – reduces overall battery investment
- **Higher efficiency** – energy losses during charging and discharging are up to 30% lower, so electricity consumption is reduced
- **Longer runtime** – thanks to more efficient battery performance and use of opportunity charges, which can be given at any time without damaging the battery or shortening its lifespan
- **Consistently high performance** – with a more constant voltage curve – maintains greater truck productivity, even toward the end of a shift
- **Faster charging** – enables full charge in as little as 1 hour with the fastest chargers
- **No battery changing** – fast opportunity charges – 15 minutes for several hours of extra runtime – enable continuous operation with just one battery and minimise the need to buy, store and maintain spares
- **No daily maintenance** – the battery stays on board the truck for charging and there is no need for water top-ups or electrolyte checks
- **No gas** – or acid spills – avoids the space, equipment and running costs of a battery room and ventilation system
- **Inbuilt protection** – intelligent battery management system (BMS) automatically prevents excessive discharge, charge, voltage and temperature, as well as virtually eliminating misuse

Batteries and chargers with different capacities are available. Your dealer will identify the best combination for your needs. You should also ask your dealer about optional 5-year warranties, subject to annual check-ups, which give extra peace of mind.

info@catliftruck.com | www.catliftruck.com

WESC124(04/21) ©2021, MLE B.V. All Rights Reserved. CAT, CATERPILLAR, LET'S DO THE WORK, their respective logos, "Caterpillar Yellow", the "Power Edge" and Cat "Modern Hex" trade dress as well as corporate and product identity used herein, are trademarks of Caterpillar and may not be used without permission.

NOTE: Performance specifications may vary depending on standard manufacturing tolerances, vehicle condition, types of tyres, floor or surface conditions, applications, or operating environment. Trucks may be shown with non-standard options. Specific performance requirements and locally available configurations should be discussed with your Cat lift trucks Dealer. Cat Lift Trucks follows a policy of continual product improvement. For this reason, some materials, options and specifications could change without notice.



**DOWNLOAD
BROCHURE**



**WATCH
VIDEOS**



**DOWNLOAD
OUR APP**

