

EQ Line

LITHION
BATTERY TECHNOLOGY



EQ LINE SPECIFICATIONS

MINI ORDER PICKER

24V, 150 KG

MN0015Q1

MORE THAN AN ORDER PICKER

**A SAFER WAY TO CLIMB
– AND A QUICKER WAY TO PICK**

Once you've tried our mini order picker, you'll wonder how you ever managed without one. It's not just an order picker: it does the job of a ladder too – but much more safely and efficiently. Highly compact and manoeuvrable, it's ideal for light to medium order picking duties in warehouses, shops and other retail settings.

CAT[®]

Characteristics			
1.1	Manufacturer		
1.2	Manufacturer's model designation		
1.3	Power source		
1.4	Operator type		
1.5	Load capacity	Q	(kg)
1.9	Wheelbase	y	(mm)
Weight			
2.1b	Truck weight without load, with maximum battery weight		kg
Wheels, Drive Train			
3.1	Tyres: PT=Power Thane, Vul=Vulkollan, P=Polyurethane, N=Nylon, R=Rubber drive/load side		
3.2	Tyre dimensions, drive side		(mm)
3.4	Castor wheel dimensions (diameter x width)		(mm)
3.5	Number of wheels, load/drive side (x=driven)		
Dimensions			
4.2a	Height with mast lowered	h1	(mm)
4.4	Lift height	h3	(mm)
4.5	Height with mast extended	h4	(mm)
4.8	Seat- or stand height	h7	(mm)
4.14	Platform height, raised	h12	(mm)
4.19	Overall length	l1	(mm)
4.21	Overall width	b1	(mm)
4.35	Turning radius	Wa	(mm)
Performance			
5.1	Travel speed, with / without load		km / h
5.2	Lifting speed, with / without load		m / s
5.3	Lowering speed, with / without load		m / s
5.8	Maximum gradeability with / without load		%
Electric motors			
6.1	Drive motor capacity (60 min. short duty)		kW
6.2	Lift motor output at 15% duty factor		kW
6.4	Battery voltage/capacity at 5-hour discharge		V / Ah
6.5	Battery weight		kg
Miscellaneous			
8.1	Type of drive control		
10.7	Level of noise at the ear level of the driver according to EN 12 053:2001 and EN ISO 4871 in work LpAZ		dB (A)
10.7.2	Whole-body vibration (EN 13 059:2002)		
10.7.3	Hand-arm vibration (EN 13 059:2002)		

Cat Lift Trucks
MN0015Q1
 Battery
 Stand-on
 90 + 150 + 130 ⁴⁾
 1145

750

P

250 x 60

180 x 50

2x / 2

1590

3000

4225

335

3000

1500

750

1300

4.5

0.14

0.13

5

0.5

2.2

24 / 100

45

DC

< 70

Refer to instruction manual

Refer to instruction manual

4) Loadweight on tray + loadweight on chassis + drivers max. weight

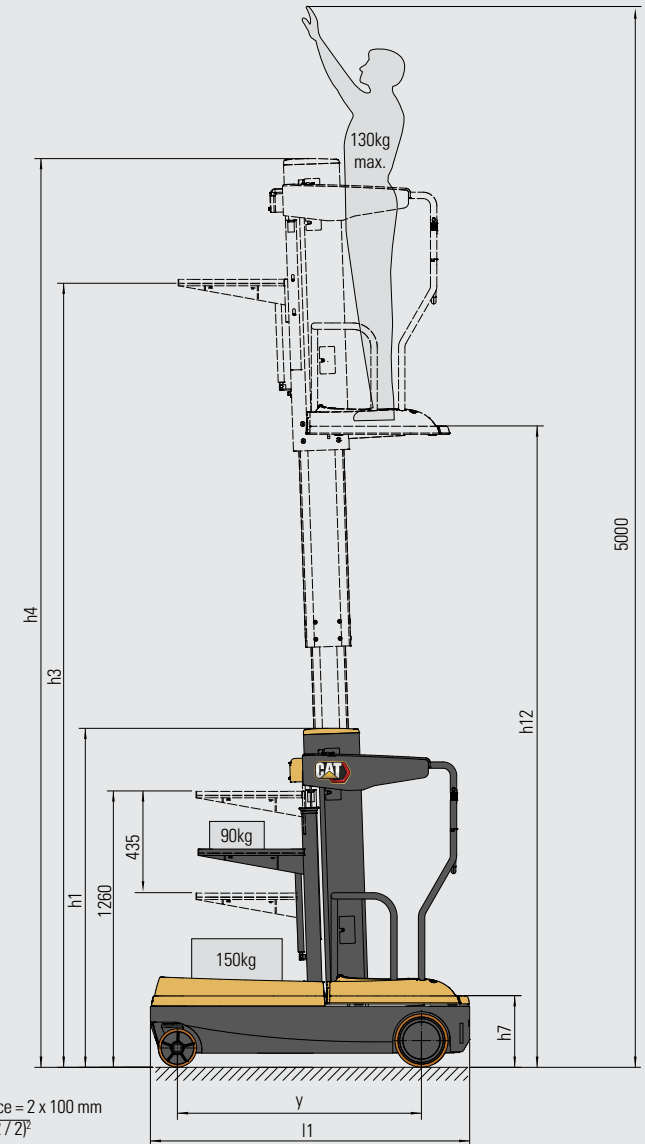

Wa = Turning radius
 a = Safety clearance = 2 x 100 mm
 $R = \sqrt{(l6 + x)^2 + (b12 / 2)^2}$
 l6 = Pallet length (800 or 1000 mm)
 b12 = Pallet width 1000 mm

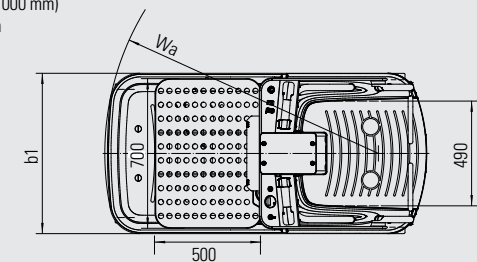

CAT LIFT TRUCKS QUALITY – FOR EVEN THE SMALLEST JOBS

Our EQ line warehouse trucks have everything you need for dependable, entry-level materials handling. That includes sturdy construction, simple maintenance, energy-efficient features, robust performance, user-friendly design, and safety. A product line for light applications. If that's what you need to get your job done, the EQ line is your perfect choice.

With our truck's stable mast and chassis, you're safe to lift the platform to 3 metres. From there, you can reach items as high as 5 metres. The load tray will take 90 kg of goods, while the load dock can carry 150 kg.

This versatile order picker works at the 1st, 2nd and 3rd racking levels. You can also use it for inspection and maintenance tasks at heights. Changing a light bulb or repairing a ceiling fixture, for example. It will even optionally transport additional loads by towing trailers.

As well as high stability, it offers a host of automatic aids to prevent falls. It will only operate if the user's hands and feet are properly in place and the safety gates are closed. Travel speed is automatically limited according to height.

Easy, precise controls and a very small turning circle make it quick to manoeuvre in tight spaces. Meanwhile, Li-ion battery technology and low maintenance needs keep it constantly available for action.

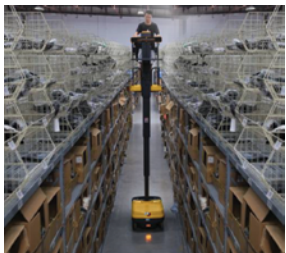

LOWER COST OF OWNERSHIP

- High-quality, robust construction ensures reliable operation over a long lifetime, with minimal servicing and repair needs.
- AC drive motor promises a long service life with low maintenance needs, thanks to elimination of brushes and commutators.
- Regenerative braking increases battery runtime, by recycling energy, and extends brake component life.
- Li-ion batteries give maximum lifespan, efficiency and runtime, with no need for water top-ups or other maintenance.
- Plug-in diagnostics and troubleshooting require only a laptop, software and a cable – not an expensive hand-held device – to reduce downtime and maintain efficient performance.
- Key switch helps avoid unauthorised use.

UNMATCHED PRODUCTIVITY

- Compact and stable design enables fast, safe performance with great manoeuvrability.
- Small footprint (750 mm wide) combines with easy steering for tight turns and flexible mobility in narrow aisles.
- Low height with mast collapsed aids passage through doorways.
- High lifting ability allows raising of platform up to 3 metres, enabling operator to reach heights up to 5 metres.
- 24V/100Ah high-capacity Li-ion battery gives powerful performance and long runtime between charges.
- Li-ion technology makes continuous operation possible, without battery changes, using fast opportunity charging during short breaks.
- Internal charger allows simple plugging in to any suitable electrical socket, wherever you are.
- BDI (battery discharge indicator) and hour meter support optimal timing of battery charging/changing.
- Towing device option adds extra versatility, allowing the truck to transport larger loads on trailers.

SAFETY AND ERGONOMICS

- Low step-in height eases platform entry and exit.
- Loading tray is positionally adjustable for convenience and has a see-through mesh construction for clear downward visibility and hence safety.
- Solid mast structure and stable chassis enable safe handling of loads at maximum lift heights.
- Safety gates prevent operator from falling from the truck.
- Automatic gate lock prevents lifting and travel if gates are open.
- Hand sensors ensure operator has both hands in place on the control handles before allowing lifting or travel.
- Operator presence sensor permits lifting/lowering and travel only if both feet are properly positioned on the platform.
- Safety harness anchor point can be used for further confidence.
- Automatic height-related travel speed reduction sets safe limits to ensure stability.
- Turtle/creep speed switch allows very slow, safe and tight manoeuvring in narrow spaces.
- Fingertip controls are simple to use and give precise, smooth adjustment of acceleration, lifting/lowering and steering.
- Emergency stop button and horn are easy to reach from the control handle.
- Amber safety lights increase truck visibility.
- Blue floor light option alerts pedestrians and other truck operators to the order picker's presence.
- Work light option enhances vision in dark areas.
- Li-ion battery chemistry means no risk of hazardous gas or acid leaks.

EQ LINE LI-ION BATTERIES

Our EQ line warehouse trucks come equipped with lithium-ion (Li-ion) battery technology.

A great advantage of Li-ion is that it allows the use of opportunity charging. Instead of exchanging batteries between shifts, you can simply plug into a fast charger during short breaks. Your business will also enjoy the other efficiency, environmental and safety benefits outlined here.



LONGER LIFE

– 3 to 4 times lead-acid lifespan –
reduces overall battery investment



FASTER CHARGING

– enables full charge in as little as
1 hour with the fastest chargers



HIGHER EFFICIENCY

– energy losses during charging and
discharging are up to 30% lower, so
electricity consumption is reduced



NO BATTERY CHANGING

– fast opportunity charging –
15 minutes for several hours of
extra runtime – makes operation
convenient with just one battery and
minimises the need to buy, store and
maintain spares



LONGER RUNTIME

– thanks to more efficient battery
performance and use of opportunity
charges, which can be given at any
time without damaging the battery or
shortening its lifespan



NO DAILY MAINTENANCE

– the battery stays on board the
truck for charging and there is
no need for water top-ups or
electrolyte checks

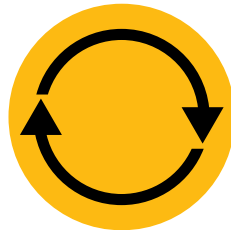

CONSISTENTLY HIGH PERFORMANCE

– with a more constant voltage curve
– maintains truck performance even
as battery charge gets low



INBUILT PROTECTION

– intelligent battery management
system (BMS) automatically
prevents excessive discharge,
charge, voltage and temperature, as
well as virtually eliminating misuse

info@catliftruck.com | www.catliftruck.com

WESC2449(02/24) © 2024 MLE B.V. (registration no. 33274459). All rights reserved. CAT, CATERPILLAR, LET'S DO THE WORK, their respective logos, "Caterpillar Yellow", the "Power Edge" and Cat "Modern Hex" trade dress as well as corporate and product identity used herein, are trademarks of Caterpillar and may not be used without permission.

NOTE: Performance specifications may vary depending on standard manufacturing tolerances, vehicle condition, types of tyres, floor or surface conditions, applications, or operating environment. Trucks may be shown with non-standard options. Specific performance requirements and locally available configurations should be discussed with your Cat lift trucks Dealer. Cat Lift Trucks follows a policy of continual product improvement. For this reason, some materials, options and specifications could change without notice.



WATCH
VIDEOS



DOWNLOAD
OUR APP

