

EQ Line

LITHION
BATTERY TECHNOLOGY

EQ LINE SPECIFICATIONS
COMPACT PEDESTRIAN STACKERS
WITH MONO MAST
24V, 1.2 TONNES

NSP12QLMI

VERSATILITY IN A SMALL PACKAGE

DO IT ALL WITH ONE LITTLE LIFT TRUCK

This economical, versatile and space-saving truck is ideal for light duties in warehouses, supermarkets and production areas. It's even small enough to take into vans and elevators. You can use it for short shuttle applications, stacking up to 1.95 metres, filling store shelves and order picking.

CAT[®]

Characteristics			
1.1	Manufacturer		
1.2	Manufacturer's model designation		
1.3	Power source		
1.4	Operator type		
1.5	Load capacity	Q	(kg)
1.6	Load centre distance	c	(mm)
1.8	Load wheel axle to fork face (forks lowered)	x	(mm)
1.9	Wheelbase	y	(mm)
Weight			
2.1b	Truck weight without load, with maximum battery weight		kg
2.2	Axle loadings with nominal load & maximum battery weight, drive / load side		kg
2.3	Axle loadings without load & with maximum battery weight, drive / load side		kg
Wheels, Drive Train			
3.1	Tyres: PT=Power Thane, Vul=Vulkollan, P=Polyurethane, N=Nylon, R=Rubber drive/load side		
3.2	Tyre dimensions, drive side		(mm)
3.3	Tyre dimensions, load side	ø	(mm)
3.4	Castor wheel dimensions (diameter x width)		(mm)
3.5	Number of wheels, load/drive side (x=driven)		
3.6	Track width (centre of tyres), drive side	b10	(mm)
3.7	Track width (centre of tyres), load side	b11	(mm)
Dimensions			
4.2a	Height with mast lowered	h1	(mm)
4.3	Free lift	h2	(mm)
4.4	Lift height (stroke)	h3+h13	(mm)
4.5	Height with mast extended	h4	(mm)
4.6	Initial lift (stroke)	h5	(mm)
4.9	Height of tiller arm / steering console (min./max.)	h14	(mm)
4.15	Fork height, fully lowered	h13	(mm)
4.19	Overall length	l1	(mm)
4.20	Length to fork face	l2	(mm)
4.21	Overall width	b1	(mm)
4.22	Fork dimensions (thickness, width, length)	s / e / l	(mm)
4.25	Outside width over forks (minimum-maximum)	b5	(mm)
4.32	Ground clearance at centre of wheelbase, (forks lowered)	m2	(mm)
4.33a	Working aisle width (Ast) with 1000 x 1200 mm pallets, load crosswise	Ast	(mm)
4.34a	Working aisle width (Ast) with 800 x 1200 mm pallets, load lengthwise	Ast	(mm)
4.35	Turning radius	Wa	(mm)
Performance			
5.1	Travel speed, with / without load		km / h
5.2	Lifting speed, with / without load		m / s
5.3	Lowering speed, with / without load		m / s
5.8	Maximum gradeability with / without load		%
5.10	Service brakes (mechanical / hydraulic / electric / pneumatic)		
Electric motors			
6.1	Drive motor capacity (60 min. short duty)		kW
6.2	Lift motor output at 15% duty factor		kW
6.4	Battery voltage/capacity at 5-hour discharge		V / Ah
6.5	Battery weight		kg
Miscellaneous			
8.1	Type of drive control		
10.7.1	Level of noise at the ear level of the driver according to EN 12 053:2001 and EN ISO 4871, drive/lift/idle LpAZ		dB (A)

Cat Lift Trucks	
NSP12QLMI	
Battery	
Pedestrian	
1200	
600	
812	
1272	
P / P	
195 x 70	
80 x 70	
150 x 60	
1x + 1 / 4	
523	
390	
2050 / 2400	
1600 / 1950	
1600 / 1950	
2060 / 2410	
120	
1150 / 1430	
1770	
619	
800	
60 / 180 / 1150	
570	
17	
2286	
2224	
1450	
4.5 / 5	
0.06 / 0.13	
0.13 / 0.10	
6 / 15	
Electric	
0.65	
2.2	
24 / 105 (120 option)	
60.8	
Stepless	
70	

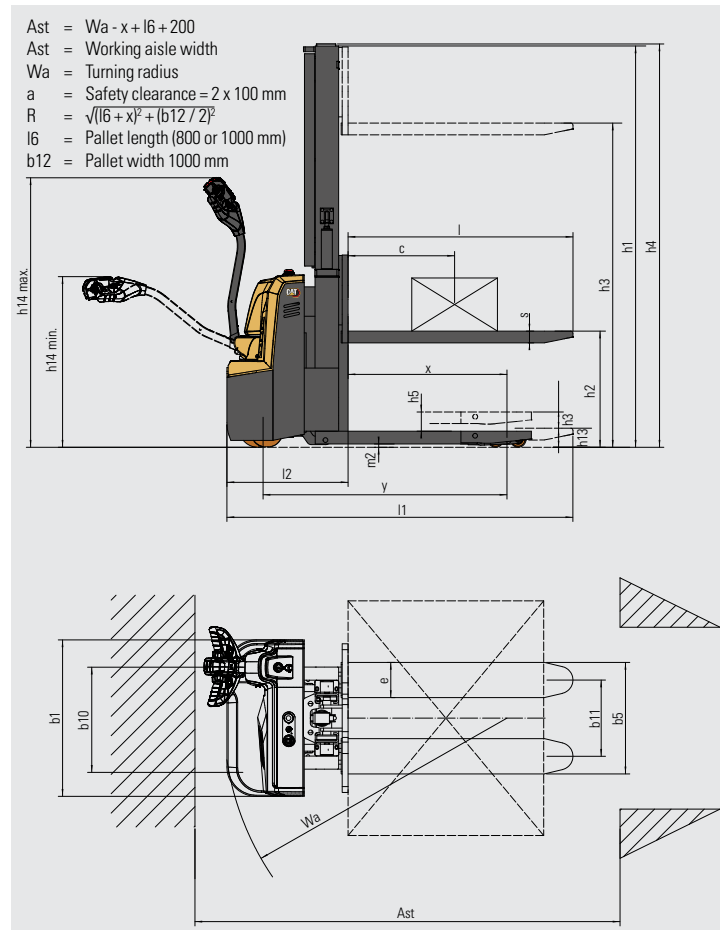

NSP12QLMI				
Mast Type	h3+h13	h1	h5	h4
	mm	mm	mm	mm
Mono	1600	2050	120	2060
	1950	2400	120	2410

Mast Performance and Capacity

- h3 = Lifting height
- h13 = Fork height, fully lowered
- h1 = Lowered mast height
- h5 = Initial lift
- h4 = Raised mast height

LOAD DERATION - NSP12QLMI		
	h3+h13	LC 600 mm
	mm	kg
Double stacker	1600	600 / 600
On forks only	1600	1200
Initial lift only	1600	1200
Double stacker	1950	600 / 600
On forks only	1950	1200
Initial lift only	1950	1200

EQLine

CAT LIFT TRUCKS QUALITY – FOR EVEN THE SMALLEST JOBS

Our EQ line warehouse trucks have everything you need for dependable, entry-level materials handling. That includes sturdy construction, simple maintenance, energy-efficient features, robust performance, user-friendly design, and safety. A product line for light applications. If that's what you need to get your job done, the EQ line is your perfect choice.

Initial lift increases ground clearance, for smooth travel over ramped and uneven surfaces. It also enables double pallet handling, with one load on the support legs and one on the forks.

A compact Li-ion battery helps to minimise overall dimensions. Highly manoeuvrable, with a tight turning circle, the truck is ideal for narrow spaces. With a clear-view mast and a small truck body, it's easy to see and position loads at ground level and upwards.

Compactness, high stability and ergonomic tiller-arm control make the truck quick and comfortable in operation. Pallet load handling is smooth and strong, thanks largely to the high-quality forks and modern AC drive motor.

Durable construction and minimal maintenance needs mean low servicing bills. Together with a low price, long service life and economical energy consumption, these factors reduce your total cost of operation (TCO).



LOWER COST OF OWNERSHIP

- High-quality, robust construction ensures reliable operation over a long lifetime, with minimal servicing and repair needs.
- Fork wheel pivot points are enclosed and protected within the fork design to avoid wear when operating on ramps.
- Durable pull rod offers extra structural strength, with high resistance to bending and deforming, for reliable performance and long life.
- Adjustable balance wheel height extends lifespan of drive wheel.
- AC drive motor promises a long service life with low maintenance needs, thanks to elimination of brushes and commutators.
- Sealing of motors reduces risk of damage by dust and water.
- Li-ion batteries give maximum lifespan, efficiency and runtime, with no need for water top-ups or other maintenance.
- Battery heating system optimises efficiency in cold environments, down to 1°C.
- Plug-in diagnostics and troubleshooting require only a laptop, software and a cable – not an expensive hand-held device – to reduce downtime and maintain efficient performance.

UNMATCHED PRODUCTIVITY

- Compact and stable design enables fast, safe performance with great manoeuvrability.
- Small size – partly due to compact Li-ion battery – combines with efficient steering for a tight turning radius and easy use in narrow aisles.
- Side castor wheels further enhance stability.
- Clear-view mono masts give excellent forward vision and are available with maximum lifts up to 1.95 metres.

- Initial lift raises mast and forks to give increased ground clearance – for better performance on ramps, dock levellers and uneven floors.
- Double pallet handling design allows lifting and carrying of two loads simultaneously, with one on the support legs and one on the forks.
- Forks with tapered tips and integral tandem polyurethane wheels enable smooth pallet entry and exit and quiet running.
- 24V/60Ah high-capacity Li-ion battery gives powerful performance and long runtime between charges.
- Li-ion technology makes continuous operation possible, without battery changes, using fast opportunity charging during short breaks.
- Internal charger allows simple plugging in to any suitable electrical socket, wherever you are.
- External charger is supplied for convenient recharging at a designated station.
- BDI (battery discharge indicator) and hour meter support optimal timing of battery charging/changing.

SAFETY AND ERGONOMICS

- Ergonomic spring-loaded tiller arm provides a comfortable grip and low-effort operation for maximum control with minimal fatigue or strain.
- Tiller arm's length keeps the operator at a safe distance, while its offset attachment to the truck body offers the possibility of walking alongside.
- Multifunctional tiller head conveniently places controls within easy reach.
- Turtle/creep speed switch allows manoeuvring with tiller arm vertical, for safe movement through narrow spaces.
- Electromagnetic brake system enhances braking performance.
- Parking brake is automatically applied when the truck stops on gradients and ramps.
- Li-ion battery chemistry means no risk of hazardous gas or acid leaks.

EQ LINE LI-ION BATTERIES

Our EQ line warehouse trucks come equipped with lithium-ion (Li-ion) battery technology.

A great advantage of Li-ion is that it allows the use of opportunity charging. Instead of exchanging batteries between shifts, you can simply plug into a fast charger during short breaks. Your business will also enjoy the other efficiency, environmental and safety benefits outlined here.



LONGER LIFE

– 3 to 4 times lead-acid lifespan –
reduces overall battery investment



FASTER CHARGING

– enables full charge in as little as
1 hour with the fastest chargers



HIGHER EFFICIENCY

– energy losses during charging and
discharging are up to 30% lower, so
electricity consumption is reduced



NO BATTERY CHANGING

– fast opportunity charging –
15 minutes for several hours of
extra runtime – makes operation
convenient with just one battery and
minimises the need to buy, store and
maintain spares



LONGER RUNTIME

– thanks to more efficient battery
performance and use of opportunity
charges, which can be given at any
time without damaging the battery or
shortening its lifespan



NO DAILY MAINTENANCE

– the battery stays on board the
truck for charging and there is
no need for water top-ups or
electrolyte checks

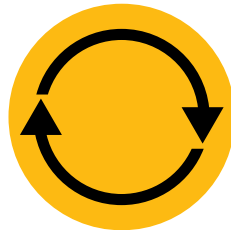

CONSISTENTLY HIGH PERFORMANCE

– with a more constant voltage curve
– maintains truck performance even
as battery charge gets low



INBUILT PROTECTION

– intelligent battery management
system (BMS) automatically
prevents excessive discharge,
charge, voltage and temperature, as
well as virtually eliminating misuse

info@catliftruck.com | www.catliftruck.com

WESC2447(02/24) © 2024 MLE B.V. (registration no. 33274459). All rights reserved. CAT, CATERPILLAR, LET'S DO THE WORK, their respective logos, "Caterpillar Yellow", the "Power Edge" and Cat "Modern Hex" trade dress as well as corporate and product identity used herein, are trademarks of Caterpillar and may not be used without permission.

NOTE: Performance specifications may vary depending on standard manufacturing tolerances, vehicle condition, types of tyres, floor or surface conditions, applications, or operating environment. Trucks may be shown with non-standard options. Specific performance requirements and locally available configurations should be discussed with your Cat lift trucks Dealer. Cat Lift Trucks follows a policy of continual product improvement. For this reason, some materials, options and specifications could change without notice.



WATCH
VIDEOS



DOWNLOAD
OUR APP

