

EQ Line

LITHION
BATTERY TECHNOLOGY

EQ LINE SPECIFICATIONS
PEDESTRIAN POWER PALLET TRUCK
24V, 1.8 TONNES

NPP180L

A COST-SAVING WORKMATE

CARRY MORE – PAY LESS

This handy little warehouse assistant takes much of the effort and expense out of moving goods. Robustly built, easy to manoeuvre, and strong enough for loads up to 1.8 tonnes, it's a reliable aid to productivity. You can expect trouble-free performance and low running costs over a long lifetime.

CAT[®]

Characteristics			
1.1	Manufacturer		
1.2	Manufacturer's model designation		
1.3	Power source		
1.4	Operator type		
1.5	Load capacity	Q	(kg)
1.6	Load centre distance	c	(mm)
1.8	Load wheel axle to fork face (forks lowered)	x	(mm)
1.9	Wheelbase	y	(mm)
Weight			
2.1b	Truck weight without load, with maximum battery weight	kg	420
2.2	Axle loadings with nominal load & maximum battery weight, drive / load side	kg	992 / 1228
2.3	Axle loadings without load & with maximum battery weight, drive / load side	kg	324 / 496
Wheels, Drive Train			
3.1	Tyres: PT=Power Thane, Vul=Vulkollan, P=Polyurethane, N=Nylon, R=Rubber drive/load side		P
3.2	Tyre dimensions, drive side	(mm)	230 x 100
3.3	Tyre dimensions, load side	(mm)	82 x 98 / 82 x 70
3.4	Castor wheel dimensions (diameter x width)	(mm)	90 x 40
3.5	Number of wheels, load/drive side (x=driven)		1x + 2/2 (4)
3.6	Track width (centre of tyres), drive side	b10	(mm) 478
3.7	Track width (centre of tyres), load side	b11	(mm) 375
Dimensions			
4.4	Lift height	h3	(mm) 120
4.9	Height of tiller arm / steering console (min./max.)	h14	(mm) 750 / 1250
4.15	Fork height, fully lowered	h13	(mm) 82
4.19	Overall length	l1	(mm) 1666
4.20	Length to fork face	l2	(mm) 516
4.21	Overall width	b1	(mm) 710
4.22	Fork dimensions (thickness, width, length)	s / e / l	(mm) 55 / 160 / 1150
4.25	Outside width over forks (minimum-maximum)	b5	(mm) 550 / 685
4.32	Ground clearance at centre of wheelbase, (forks lowered)	m2	(mm) 27
4.33a	Working aisle width (Ast) with 1000 x 1200 mm pallets, load crosswise	Ast	(mm) 2302
4.34a	Working aisle width (Ast) with 800 x 1200 mm pallets, load lengthwise	Ast	(mm) 2156
4.35	Turning radius	Wa	(mm) 1504
Performance			
5.1	Travel speed, with/without load	km/h	5.8 / 6
5.2	Lifting speed, with/without load	m/s	0.03 / 0.038
5.3	Lowering speed, with/without load	m/s	0.04 / 0.036
5.8	Maximum gradeability with / without load	%	8 / 20
5.10	Service brake		Electric
Electric motors			
6.1	Drive motor capacity (60 min. short duty)	kW	1.2
6.2	Lift motor output at 15% duty factor	kW	0.8
6.4	Battery voltage/capacity at 5-hour discharge	V / Ah	24 / 160
6.5	Battery weight	kg	170
Miscellaneous			
8.1	Type of drive control		Stepless
10.7.1	Level of noise at the ear level of the driver according to EN 12 053:2001 and EN ISO 4871, drive/lift/idle LpAZ	dB(A)	70
10.7.2	Whole-body vibration (EN 13 059:2002)		Refer to instruction manual
10.7.3	Hand-arm vibration (EN 13 059:2002)		<2.5

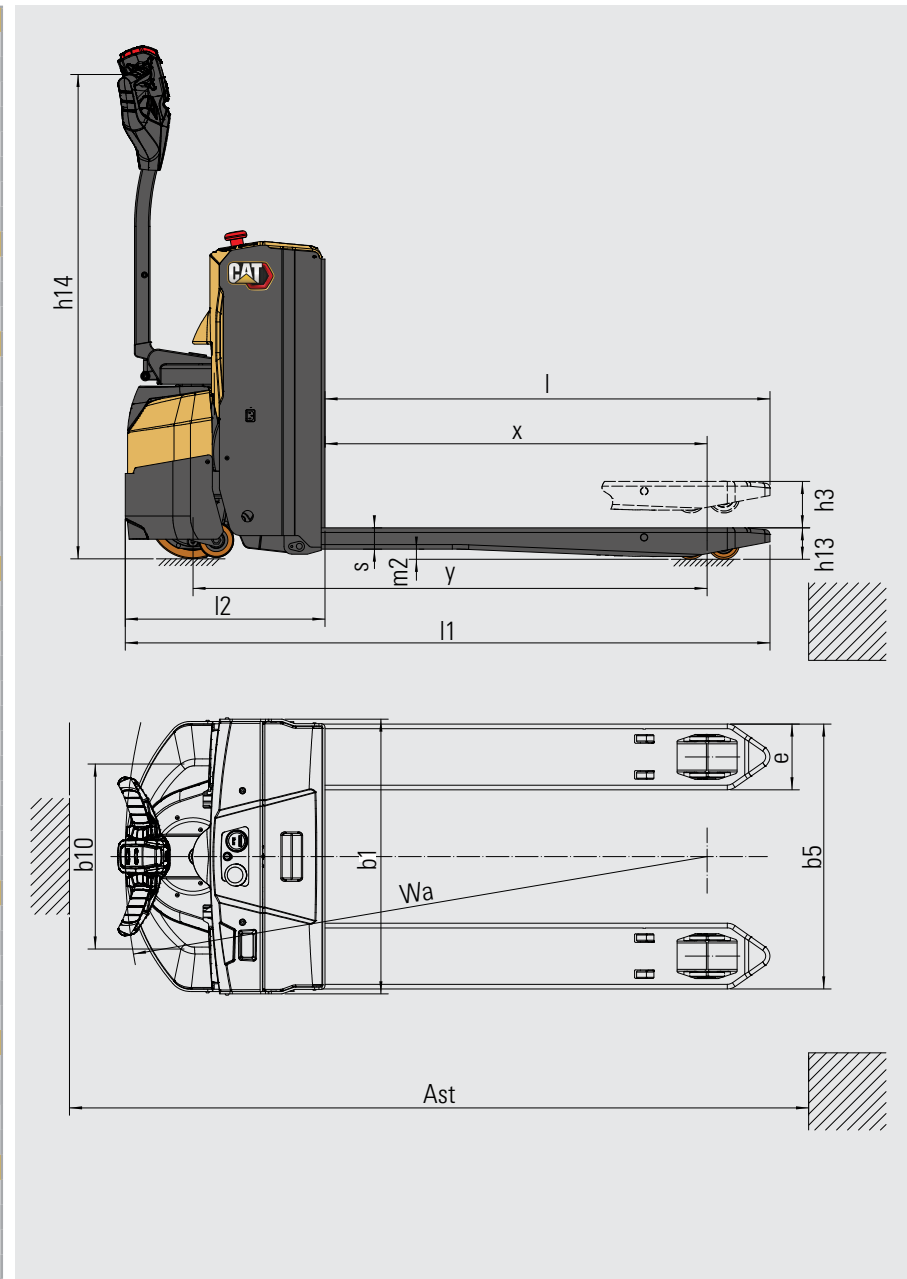

EQLine

CAT LIFT TRUCKS QUALITY – FOR EVEN THE SMALLEST JOBS

Our EQ line warehouse trucks have everything you need for dependable, entry-level materials handling. That includes sturdy construction, simple maintenance, energy-efficient features, robust performance, user-friendly design, and safety. A product line for light applications. If that's what you need to get your job done, the EQ line is your perfect choice.

Compact size, high stability and ergonomic tiller-arm control make the truck quick and comfortable in operation. Pallet load handling is smooth and strong, thanks largely to the high-quality forks and modern AC drive motor.

Li-ion battery technology and flexible, convenient charging ensure maximum productive action. There's even a battery heating system to ensure efficient performance on cold days.

Durable construction and minimal maintenance needs mean low servicing bills. Together with a low price, long service life and economical energy consumption, these factors reduce your total cost of operation (TCO).



LOWER COST OF OWNERSHIP

- High-quality, robust construction ensures reliable operation over a long lifetime, with minimal servicing and repair needs.
- High-strength 6 mm manganese steel forks resist deformation.
- Fork wheel pivot points are enclosed and protected within the fork design to avoid wear when operating on ramps.
- Durable pull rod offers extra structural strength, with high resistance to bending and deforming, for reliable performance and long life.
- AC drive motor promises a long service life with low maintenance needs.
- Electromagnetic braking extends brake component life.
- Li-ion batteries give maximum lifespan, efficiency and runtime, with no need for water top-ups or other maintenance.
- Battery heating system optimises efficiency in cold environments, down to 1°C.
- Plug-in diagnostics and troubleshooting require only a laptop, software and a cable – not an expensive hand-held device – to reduce downtime and maintain efficient performance.

UNMATCHED PRODUCTIVITY

- Compact and stable design enables fast, safe performance with great manoeuvrability.
- Side castor wheels further enhance stability.
- Forks with tapered tips and integral polyurethane wheels enable smooth pallet entry and exit and quiet running.
- Guide markings on forks help in correct pallet loading.
- 24V/100Ah high-capacity Li-ion battery gives powerful performance and long runtime between charges.

- Li-ion technology makes continuous operation possible, without battery changes, using fast opportunity charging during short breaks.
- Internal charger (optional) allows simple plugging in to any suitable electrical socket, wherever you are.
- External charger is supplied for convenient recharging at a designated station.
- Sideways battery exchange requires no additional tools or devices and takes just 10 seconds.
- BDI (battery discharge indicator) and hour meter support optimal timing of battery charging/charging.

SAFETY AND ERGONOMICS

- Ergonomic spring-loaded tiller arm provides a comfortable grip and low-effort operation for maximum control with minimal fatigue or strain.
- Multifunctional tiller head conveniently places controls within easy reach.
- Turtle/creep speed switch allows manoeuvring with tiller arm vertical, for safe movement through narrow spaces.
- Electromagnetic brake system enhances braking performance.
- Parking brake is automatically applied when the truck stops on gradients and ramps.
- Li-ion battery chemistry means no risk of hazardous gas or acid leaks.

EQ LINE LI-ION BATTERIES

Our EQ line warehouse trucks come equipped with lithium-ion (Li-ion) battery technology.

A great advantage of Li-ion is that it allows the use of opportunity charging. Instead of exchanging batteries between shifts, you can simply plug into a fast charger during short breaks. Your business will also enjoy the other efficiency, environmental and safety benefits outlined here.



LONGER LIFE

– 3 to 4 times lead-acid lifespan –
reduces overall battery investment



FASTER CHARGING

– enables full charge in as little as
1 hour with the fastest chargers



HIGHER EFFICIENCY

– energy losses during charging and
discharging are up to 30% lower, so
electricity consumption is reduced



NO BATTERY CHANGING

– fast opportunity charging –
15 minutes for several hours of
extra runtime – makes operation
convenient with just one battery and
minimises the need to buy, store and
maintain spares



LONGER RUNTIME

– thanks to more efficient battery
performance and use of opportunity
charges, which can be given at any
time without damaging the battery or
shortening its lifespan



NO DAILY MAINTENANCE

– the battery stays on board the
truck for charging and there is
no need for water top-ups or
electrolyte checks

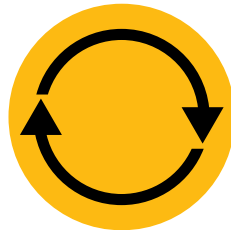

CONSISTENTLY HIGH PERFORMANCE

– with a more constant voltage curve
– maintains truck performance even
as battery charge gets low



INBUILT PROTECTION

– intelligent battery management
system (BMS) automatically
prevents excessive discharge,
charge, voltage and temperature, as
well as virtually eliminating misuse

info@catliftruck.com | www.catliftruck.com

WESC2444(02/24) © 2024 MLE B.V. (registration no. 33274459). All rights reserved. CAT, CATERPILLAR, LET'S DO THE WORK, their respective logos, "Caterpillar Yellow", the "Power Edge" and Cat "Modern Hex" trade dress as well as corporate and product identity used herein, are trademarks of Caterpillar and may not be used without permission.

NOTE: Performance specifications may vary depending on standard manufacturing tolerances, vehicle condition, types of tyres, floor or surface conditions, applications, or operating environment. Trucks may be shown with non-standard options. Specific performance requirements and locally available configurations should be discussed with your Cat lift trucks Dealer. Cat Lift Trucks follows a policy of continual product improvement. For this reason, some materials, options and specifications could change without notice.



WATCH
VIDEOS



DOWNLOAD
OUR APP

