



NVT11
NVT12
NVT13
NVT14
NVT15
NVT15XL*
NVT20*

THE PERFECT FIT

PRELIMINARY SPECIFICATIONS

MAN-UP TURRET TRUCKS 48/80V, 1.1 - 2.0 TONNES



MODULAR FLEXIBILITY FOR MAXIMUM WAREHOUSE EFFICIENCY

PERFECT FOR STACKING AND ORDER PICKING IN VERY NARROW AISLES AND HIGH RACKING, THESE TRUCKS ARE CUSTOMISABLE TO FIT YOUR SPACE, LOAD AND OPERATOR NEEDS PRECISELY. SUPERIOR ERGONOMICS AND COMFORT MAKE OPERATION A PLEASURE, WHILE POWERFUL PERFORMANCE AND LOW RUNNING COSTS BOOST PROFITS.



The seven-model NVT range covers lifting heights up to 19 metres* and capacities between 1.1 and 2.0 tonnes. Thanks to modular engineering, each model can be adapted almost infinitely to meet the specific requirements of your premises and application.

For optimum space utilisation, overall truck width can be specified at anything from 1.0 to 1.9 metres – in steps of 5 centimetres or even less. A variety of masts and swivelling or telescopic forks can be chosen for different loads and racking arrangements.

Advanced design technology reduces mast, cabin and chassis weights, for faster and more energy-efficient performance, but optimises stability. Each truck component, system or structure is also designed for low wear, high protection and minimal maintenance demands.

The comfortable and ergonomically equipped cabin can be fitted with one of several console options and layouts to suit the operator and business. Use of the controls and easy-to-read display is simple and highly intuitive.

* NVT15XL and NVT20 models are available on request for specific applications. 19 metre lift height is only possible with NVT15XL.

LOWER COST OF OWNERSHIP

- Low-weight design reduces energy consumption and wear, as well as enhancing performance.
- Separate proportional valve regulates cabin lowering speed more efficiently, for longer battery runtime, and extends component life.
- Low centre of gravity and lightweight construction avoid need for load wheel brakes, which would require regular adjustment, servicing, and replacement of worn parts.
- Adjustable load wheel height allows easy compensation for differences in wear between wheels or if one wheel is damaged, so no need to replace as pairs.
- Lubrication points improve performance and longevity of all cabin and mast bearings.
- Large spacing between auxiliary lifting mast bearings reduces deflection, lowers bearing stresses and increases durability.
- Large, closed wheel arches combine with guide rollers to protect load wheels from damage.
- Steering chain is adjustable, less sensitive to dirt and much more wear-resistant than the spur gear alternative.
- Strong steel doors enclose motor compartment, protect internal components – including electronic controls – and open to give easy, uncluttered access for servicing.
- Rapid fault analysis is possible via LED displays, PC connection or, remotely, through GSM mobile communication, to simplify and speed up repairs and maintenance.
- Long replacement intervals cut time and material costs for items like mast chains and hydraulic oil.
- Battery change is quick and easy using a counterbalance lift truck.

UNMATCHED PRODUCTIVITY

- Flexible choice of cabin and chassis dimensions – in small increments – allows perfect fit with different aisles, applications and batteries.
- Latest AC drive technology generates fast lifting speeds for forks, masts and cabins, with low energy losses.
- Advanced mast design uses FEM (finite element method) to optimise stability, weight and performance.
- Duplex mast choices for all lift heights mean faster and more stable performance, lower energy consumption, less maintenance and shorter truck length than with triplex.
- Triplex mast options include versions without full free lift, for higher speed and lower maintenance.
- Fork range includes mast swivel and telescopic types suited to different specific applications.

SAFETY AND ERGONOMICS

- Mast-to-chassis struts increase mast rigidity, while low centre of gravity maximises overall truck stability.
- Clear all-round views are aided by excellent through-mast visibility, angled motor compartment and rounded chassis.
- Optional tilting side gates open with a flip of the upper bar for easy order picking.
- Thin front wall allows easy reach to place picked items into container or onto pallet.
- Spacious and secure cabin features carpeted walls, thickly cushioned floor, high-comfort seat (with weight adjustment) and inbuilt document and equipment holders as standard.
- Wide range of seating options and accessories includes folding version for choice of standing or sitting operation, with pneumatic spring mechanism for easy switching of console between positions.
- Choice of operator console styles and layouts is matched to different needs and preferences, enabling easy reach and use of controls (and clear display screen) in all cases.



STANDARD EQUIPMENT AND OPTIONS

	NVT11	NVT12	NVT13	NVT14	NVT15	NVT15XL	NVT20
GENERAL							
Overhead guard with 4 LED spot	●	●	●	●	●	●	●
Mirrors	●	●	●	●	●	●	●
Emergency rope	●	●	●	●	●	●	●
Control panel with ball handle bar	●	●	●	●	●	●	●
Higher side shift speed	●	●	●	●	●	●	●
CHASSIS							
Special paint, change of one colour (Standard RAL)	○	○	○	○	○	○	○
Extended or shortened chassis	○	○	○	○	○	○	○
Twin/dual load wheels, minimum chassis width 1450 mm	○	○	○	○	○	○	○
NVT14 with NVT15 chassis, battery up to 5 PzS 700/775 Ah	○	○	○	○	○	○	○
NVT15 with chassis for battery 6 PzS 840/930 Ah, special drive wheel	○	○	○	○	○	○	○
Rail guidance for standard profile, minimum 80 mm profile height	○	○	○	○	○	○	○
Rail guidance, minimum 38 mm profile height	○	○	○	○	○	○	○
Side guide rollers antistatic	○	○	○	○	○	○	○
Additional side guide roller in the centre of truck (3 rollers on each side)	○	○	○	○	○	○	○
Inductive wire guidance 6.25 kHz +/- 30 Hz, 78 mA	○	○	○	○	○	○	○
Line driver for max 1200 m wire, 6.25 kHz	○	○	○	○	○	○	○
MAST							
Fork carriage width 850 mm	○	○	○	○	○	○	○
Fork carriage width 1150 mm	○	○	○	○	○	○	○
Head centre distance 700 mm (less capacity)	○	○	○	○	○	○	○
Head centre distance 750/800 mm (less capacity)	○	○	○	○	○	○	○
Shorten mast, special closed heights	○	○	○	○	○	○	○
Full fork carriage for swivel fork 320, 850 mm for distance across forks 240 - 795 mm	○	○	○	○	○	○	○
Hydraulic fork adjustment, 500 - 800 mm, integrated, width of fork carriage 1080 mm	○	○	○	○	○	○	○
Side shifter +/- 100 mm	○	○	○	○	○	○	○
Telescopic fork, width 1200 mm, supplementary lift 650 mm	○	○	○	○	○	○	○
Telescopic fork, width 1200 mm, supplementary lift > 650 mm	○	○	○	○	○	○	○
Telescopic fork, width 1200 mm, supplementary lift > 650 mm, profiles in front of the load, max 1000 kg, no cold store	○	○	○	○	○	○	○
Telescopic forks, lowered height 190 mm, max capacity 1000 kg	○	○	○	○	○	○	○
Supplementary lift height 1700 mm with swivel fork type MSG 320	○	○	○	○	○	○	○
Supplementary lift height 2100 or 2300 mm with swivel fork type MSG 320	○	○	○	○	○	○	○
NVT15 with swivel fork type MSG 120, supplementary lift 1500 mm	○	○	○	○	○	○	○
NVT15 with swivel fork type MSG 120, guidance at overhead guard, supplementary lift 1500 mm	○	○	○	○	○	○	○
CABIN							
Control panel with rotary switches	○	○	○	○	○	○	○
Control panel with single lever	○	○	○	○	○	○	○
Control panel with multifunction lever	○	○	○	○	○	○	○
Tilting panel for order picking (only possible with ball handle bar or rotary switch)	○	○	○	○	○	○	○
Spilt control panel at the back, beside the seat, including armrests	○	○	○	○	○	○	○
Multicheck with PIN-code access, 10 different codes, hour counter for week and day	○	○	○	○	○	○	○
12 or 24 volt connection with separate DC converter	○	○	○	○	○	○	○
24 volt connection behind ignition lock, max 2 ampere	○	○	○	○	○	○	○

● Standard ○ Option

STANDARD EQUIPMENT AND OPTIONS

	NVT11	NVT12	NVT13	NVT14	NVT15	NVT15XL	NVT20
USB Connection 5 V (USB-A and USB-C) in cabin	○	○	○	○	○	○	○
Armrests, adjustable	○	○	○	○	○	○	○
Heated seat	○	○	○	○	○	○	○
Air suspension seat	○	○	○	○	○	○	○
Swivel seat	○	○	○	○	○	○	○
2 additional LED working lights at both sides of the overhead guard	○	○	○	○	○	○	○
2 powerful LED lighting strips at left and right side of overhead guard	○	○	○	○	○	○	○
Flashing light at the mast	○	○	○	○	○	○	○
Blue spot at the mast to the rear, functioning when travelling backwards	○	○	○	○	○	○	○
Simultaneous lifting of main and supplementary lift	○	○	○	○	○	○	○
Clipboard DIN A4 in the cabin	○	○	○	○	○	○	○
Clipboard DIN A4 at universal fastening rail	○	○	○	○	○	○	○
Height level positioning system (10 levels) with indicator, for cabin lift (not together with PIN-code system)	○	○	○	○	○	○	○
Overload indicator	○	○	○	○	○	○	○
Digital scale, +/- 25 kg, measurement by hydraulic pressure of supplementary lift mast	○	○	○	○	○	○	○
Fan in cabin	○	○	○	○	○	○	○
Swivel /tilting side gates, specially for order picking	○	○	○	○	○	○	○
Tray for universal fastening rail	○	○	○	○	○	○	○
Acoustic signal when driving backwards	○	○	○	○	○	○	○
Speed control unit GSG2 for linear driving speeds depending on lift height, programmable lift stop above 500 mm	○	○	○	○	○	○	○
Windscreen removable	○	○	○	○	○	○	○
Makrolon screen on the overhead guard	○	○	○	○	○	○	○
Makrolon window in front of the control panel (only for EK 1500 with swivel fork type 120)	○	○	○	○	○	○	○
Makrolon cabin, windscreen removable	○	○	○	○	○	○	○
Cabin heating	○	○	○	○	○	○	○
INTERLOCKS							
Slow down at the end of aisle, without stop	○	○	○	○	○	○	○
Slow down and stop at the end of aisle	○	○	○	○	○	○	○
Magnets per aisle	○	○	○	○	○	○	○
Electrical drive and lift cut-out with overriding switch	○	○	○	○	○	○	○
Electrical drive and lift cut-out with overriding switch outside the aisle	○	○	○	○	○	○	○
Electrical reach cut-out for swivel head MSG 320	○	○	○	○	○	○	○
Zone-dependent interlocks	○	○	○	○	○	○	○
Driving outside the guidance up to maximum lift height with override switch, 2.5 km/h, drive wheel in straight position	○	○	○	○	○	○	○
BATTERY							
Battery frame additional for fast and easy battery change with counterbalance truck	○	○	○	○	○	○	○
Battery rollers in truck	○	○	○	○	○	○	○
Spare Battery roller station for charging outside of truck	○	○	○	○	○	○	○
Mobile winch for battery change for fixing at the chassis	○	○	○	○	○	○	○
Battery cable for battery changing	○	○	○	○	○	○	○
COLD STORE							
Cold store application, without cabin	○	○	○	○	○	○	○
Cabin for cold store applications	○	○	○	○	○	○	○
Inductive wire guidance 6.25 kHz +/- 30 Hz, 78 mA +/- 15%, Zapi	○	○	○	○	○	○	○
Lifting jack for relieving the driving wheel when battery is loading	○	○	○	○	○	○	○
48/80 volt supply for the night (converter not for cold store area, without cable)	○	○	○	○	○	○	○
Telescopic forks for cold store application	○	○	○	○	○	○	○
SAFETY							
Preparation for installing personal safety system with laser scanner	○	○	○	○	○	○	○
Personal safety system with 2 laser scanner, SSZ	○	○	○	○	○	○	○

● Standard ○ Option

Characteristics		
1.1	Manufacturer	
1.2	Manufacturer's model designation	
1.3	Power source	
1.4	Operator type	
1.5	Load capacity	Q (kg)
1.6	Load centre distance	c (mm)
1.9	Wheelbase	y (mm)
Weight		
2.1	Weight including battery without load	kg
2.2	Axle loadings with nominal load & maximum battery weight, drive / load side	kg
2.3	Axle loadings without load & with maximum battery weight, drive / load side	kg
Wheels, Drive Train		
3.1	Tyres: PT = Power Thane, Vul = Vulkollan, P = Polyurethane, N = Nylon, R = Rubber drive / load side	
3.2	Tyre dimensions, drive side	(mm)
3.3	Tyre dimensions, load side	(mm)
3.5	Number of wheels, load / drive side (x = driven)	
Dimensions		
4.2a	Height with mast lowered	h1 (mm)
4.4	Lift height	h3G + h13(mm)
4.5	Height with mast extended	h4 (mm)
4.7	Height to top of overhead guard	h6 (mm)
4.8	Seat- or stand height	h7 (mm)
4.11	Supplementary lift	h9 (mm)
4.14a	Platform height, raised	h12 (mm)
4.15	Fork height, fully lowered	h13 (mm)
4.22	Fork dimensions (thickness, width, length)	s / e / l (mm)
4.22b	Fork dimensions (length)	l (mm)
4.25	Outside width over forks (fork carrier width 580/850 mm)	b5 (mm)
4.32	Ground clearance at center of wheelbase, (forks lowered)	m2 (mm)
4.33a	Working aisle width (Ast) with 1000 x 1200 mm pallets, load crosswise	Ast (mm)
4.34a	Working aisle width (Ast) with 800 x 1200 mm pallets, load lengthwise	Ast (mm)
4.35	Turning radius	Wa (mm)
Performance		
5.1	Travel speed, with / without load	km / h
5.2	Lifting speed, with / without load	m / s
5.3	Lowering speed, with / without load	m / s
5.4	Reach speed laden/unladen (adjustable)	m / s
5.10	Service brakes (mechanical / hydraulic / electric / pneumatic)	
Electric motors		
6.1	Drive motor	kW
6.2	Lift motor	kW
6.4	Battery voltage/capacity at 5-hour discharge	V / Ah
6.5	Battery weight	kg
Miscellaneous		
8.1	Type of drive control	

	Cat Lift Trucks NVT15	Cat Lift Trucks NVT15XL	Cat Lift Trucks NVT20
Battery	Battery	Battery	Battery
Standing/Seated	Standing/Seated	Standing/Seated	Standing/Seated
Load capacity	1500	1500	2000
Load centre distance	600	600	600
Wheelbase	2140	2140	2140
Weight including battery without load	7100 - 8700	8900 - 9400	7400 - 8900
Axle loadings with nominal load & maximum battery weight, drive / load side	2300/6300; 2950/7250	3000/7400; 3100/7800	2100/7300; 2700/8200
Axle loadings without load & with maximum battery weight, drive / load side	2900/4200; 3550/5150	3500/5400; 3700/5700	3000/4400; 3400/5400
Tyres	P	P	P
Tyre dimensions, drive side	381/152	381/152	381/152
Tyre dimensions, load side	377/178	377/178	377/178
Number of wheels, load / drive side (x = driven)	2/1x	2/1x	2/1x
Height with mast lowered	See table	See table	See table
Lift height	See table	See table	See table
Height with mast extended	See table	See table	See table
Height to top of overhead guard	See table	See table	See table
Seat- or stand height	See table	See table	See table
Supplementary lift	1900	1900	1500
Platform height, raised	See table	See table	See table
Fork height, fully lowered	90	90	90
Fork dimensions (thickness, width, length)	40/120 / 800 - 1300	40/120 / 800 - 1300	40/120 / 800 - 1300
Fork dimensions (length)	800 - 1300	800 - 1300	800 - 1300
Outside width over forks (fork carrier width 580/850 mm)	530/505 - 795	530/505 - 795	240 - 795
Ground clearance at center of wheelbase, (forks lowered)	40	40	40
Working aisle width (Ast) with 1000 x 1200 mm pallets, load crosswise	See table	See table	See table
Working aisle width (Ast) with 800 x 1200 mm pallets, load lengthwise	See table	See table	See table
Turning radius	2445	2445	2445
Travel speed, with / without load	12.0/12.0	12.0/12.0	12.0/12.0
Lifting speed, with / without load	0.48/0.52 ¹⁾	0.44/0.52 ¹⁾	0.48/0.56 ¹⁾
Lowering speed, with / without load	0.45/0.45	0.45/0.45	0.45/0.45
Reach speed laden/unladen (adjustable)	up to 0.45 ⁴⁾	up to 0.45 ⁴⁾	0.20 / 0.20
Service brakes (mechanical / hydraulic / electric / pneumatic)	Electric	Electric	Electric
Drive motor	7.0	7.0	7.0
Lift motor	21.0 ¹⁾	32.0	32.0 ¹⁾
Battery voltage/capacity at 5-hour discharge	80 Volt / 775 ³⁾	80 Volt / 775 ³⁾	80 Volt / 775 ³⁾
Battery weight	1862	1862	1862
Type of drive control	Stepless	Stepless	Stepless

- 1) Higher lift speeds on request
- 2) Also available in 80 volt
- 3) Other capacities on request
- 4) Adjustable

T1	Overhang	x/x1 (mm)
T2	Picking height	(mm)
T3	Overall width (in 50 mm steps)	b1 (mm)
T4	Overall length with fork carrier width 850 mm	l1 (mm)
T5	Overall length with fork carrier width 580 mm	l1 (mm)
T6	Support boom length (standard)	M1S (mm)

	NVT15	NVT15XL	NVT20
Overhang	360 / 270	360 / 270	360 / 270
Picking height	h12 + 1600	h12 + 1600	h12 + 1600
Overall width (in 50 mm steps)	1200 - 1700	1600 - 1900	1200 - 1700
Overall length with fork carrier width 850 mm	3650 - 3740 - 3840	3650 - 3740 - 3840	3740 - 3840
Overall length with fork carrier width 580 mm	3515 - 3605 - 3705	3515 - 3605 - 3705	3605 - 3705
Support boom length (standard)	460 - 550 - 650	460 - 550 - 650	550 - 650

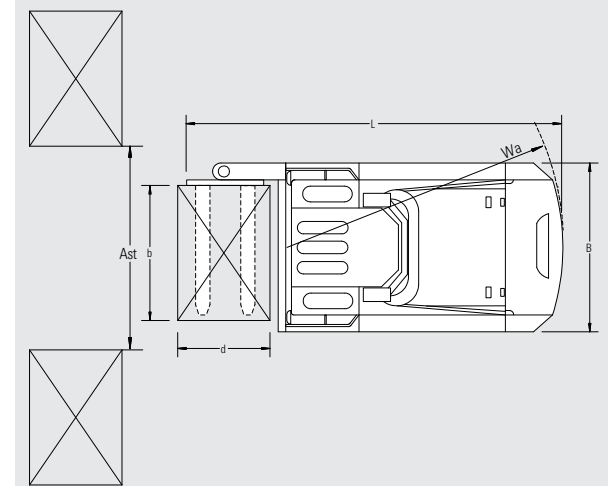
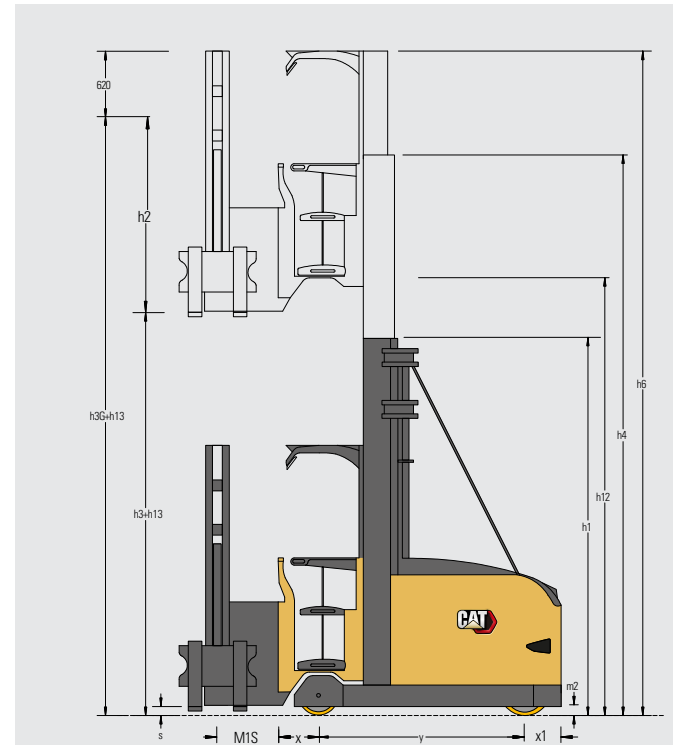

Ast = Wa - x + h6 + 200
 Ast = Working aisle width
 Wa = Turning radius

Build and lift heights of duplex lift mast with swivel fork, supplementary lift 1900 mm or 2300 mm (optional)

					NVT11 - NVT13	NVT14/NVT15	NVT15XL	NVT20
Total lift height with 1900 mm suppl. lift	Total lift height with 2300 mm suppl. lift	Cabin lift height	Raised platform height	Extended height cabin**	Closed height 2-stage mast*	Closed height 2-stage mast*	Closed height 2-stage mast	Closed height 2-stage mast***
h3G+h13 mm	h3G+h13 mm	h3+h13 mm	h12 mm	h6 mm	h1 mm	h1 mm	h1 mm	h1 mm
4400	4800	2500	2820	5020	2600	-	-	-
4900	5300	3000	3320	5520	2745	-	-	-
5400	5800	3500	3820	6020	2995	2920	-	3170
5900	6300	4000	4320	6520	3245	3170	-	3420
6400	6800	4500	4820	7020	3495	3420	-	3670
6900	7300	5000	5320	7520	3745	3670	-	3920
7400	7800	5500	5820	8020	3995	3920	-	4170
7900	8300	6000	6320	8520	4245	4170	-	4420
8400	8800	6500	6820	9020	4495	4420	-	4670
8900	9300	7000	7320	9520	4745	4670	-	4920
9400	9800	7500	7820	10020	4995	4920	-	5170
9900	10300	8000	8320	10520	5245	5170	-	5420
10400	10800	8500	8820	11020	-	5420	-	5670
10900	11300	9000	9320	11520	-	5670	-	5920
11400	11800	9500	9820	12020	-	5920	-	6170
11900	12300	10000	10320	12520	-	6170	-	6420
12400	12800	10500	10820	13020	-	6420	-	6670
12900	13300	11000	11320	13520	-	6670	-	6920
13400	13800	11500	11820	14020	-	6920	-	7170
13900	14300	12000	12320	14520	-	7170	7420	-
14400	14800	12500	12820	15020	-	-	7670	-
14900	15300	13000	13320	15520	-	-	7920	-
15400	15800	13500	13820	16020	-	-	8170	-
15900	16300	14000	14320	16520	-	-	8420	-

*NVT11 maximum closed height 4745 mm; **NVT14 maximum closed height 6170 mm; other closed/lift heights on request.
 Extended height with 2300 mm suppl. lift + 600 mm; *NVT20 reduced total lift heights, supplementary lift = 1500 mm; other heights on request.



info@catlifttruck.com | www.catlifttruck.com

WESC2011(04/26) © 2026 Logisnext Europe B.V. All rights reserved. CAT, CATERPILLAR, LET'S DO THE WORK, and their respective logos "Caterpillar Corporate Yellow", the "Power Edge" and Cat "Modern Hex" trade dress as well as corporate and product identity used herein are trademarks of Caterpillar used under license and may not be used without permission from Caterpillar. Specifications are indicative and may vary depending on operating conditions. Failure to assess all factors may result in performance deviations. All relevant sales support materials and technical expertise of the official distributor must be considered when identifying the best product/solution. Options and technical details may change without notice. Full legal notice and up-to-date product information: www.catlifttruck.com.

Build and lift heights of triplex lift mast with swivel fork, supplementary lift 1900 mm or 2300 mm (optional)

					NVT11 - NVT13	NVT14/NVT15	NVT15XL
Total lift height with 1900 mm suppl. lift	Total lift height with 2300 mm suppl. lift	Cabin lift height	Raised platform height	Extended height cabin**	Closed height 3-stage mast*	Closed height 3-stage mast	Closed height 3-stage mast
h3G+h13 mm	h3G+h13 mm	h3+h13 mm	h12 mm	h6 mm	h1 mm	h1 mm	h1 mm
5650	6050	3750	4070	6270	2600	-	-
6400	6800	4500	4820	7020	2745	-	-
7150	7550	5250	5570	7770	2995	2920	-
7900	8300	6000	6320	8520	3245	3170	-
8650	9050	6750	7070	9270	3495	3420	-
9400	9800	7500	7820	10020	3745	3670	-
10150	10550	8250	8570	10770	3995	3920	-
10900	11300	9000	9320	11520	-	4170	-
11650	12050	9750	10070	12270	-	4420	-
12400	12800	10500	10820	13020	-	4670	4920
13150	13550	11250	11570	13770	-	4920	5170
13900	14300	12000	12320	14520	-	5170	5420
14650	15050	12750	13070	15270	-	5420	5670
15400	15800	13500	13820	16020	-	-	5920
16150	16550	14250	14570	16770	-	-	6170

*NVT11 maximum closed height 3495 mm; **extended height with 2300 mm suppl. lift + 400 mm; other closed/lift heights on request.
 Overall length with triplex mast: NVT11/12/13 is 35 mm longer; NVT14/15 is 125 mm longer; NVT14 closed height > 4170 mm same length as NVT15.

Aisle width depending on load/pallet dimensions

Load dimensions				NVT11	NVT12/NVT13	NVT14	NVT15/NVT20
Depth	Width	Distance between loads**	Boom length	Transfer aisle width*	Transfer aisle width*	Transfer aisle width*	Transfer aisle width*
mm	mm	Ast mm	M1S mm	mm	mm	mm	mm
1240	835	1700	460	3480	3530	3595	3820
1200	800	1650	460	3460	3510	3575	3800
1200	1000	1650	550	3540	3600	3655	3890
1200	1200	1650	650	3630	3690	3745	3980
1000	800	1450	460	3380	3440	3495	3730
1000	1000	1450	550	3460	3520	3585	3820
1000	1200	1450	650	3560	3610	3675	3910
800	800	1400	460	3360	3420	3485	3710
800	1000	1400	550	3450	3500	3565	3800
800	1200	1400	650	3540	3600	3655	3900
835	1240	1400	650	3540	3600	3655	3900

*Transfer aisle width without load and 580 mm fork carriage width, with mechanical guidance + 300 mm, with wire guidance + 800 mm recommended.
 Aisle width for mechanical guidance and duplex mast; reduced truck lengths on request. ** NVT20 + 50 mm.



DOWNLOAD
BROCHURE



WATCH
VIDEOS



DOWNLOAD
OUR APP

