



CV25MNTN
CV25MNSN
CV25MPSP
CV25MRTP
CV25MPTP
CV25IPTP
CV25IRTP

CV30MPTP

ADDED VALUE

SPECIFICATIONS

HAND PALLET TRUCKS 2.5 – 3.0 TONNES



THE ECONOMICAL CHOICE FOR SHORT-DISTANCE TRANSPORTATION

OUR ECONOMY HAND PALLET TRUCK COMES EQUIPPED WITH ALL THAT IS NEEDED TO PROVIDE GOOD LONG-TERM PERFORMANCE AT AN INEXPENSIVE PRICE.



With a load capacity of 2.5 – 3.0 tonnes, this durable hand pallet truck increases productivity and efficiency in warehouse and retail applications, providing you with the most economical choice for short-distance transportation.

Rounded fork tips

fork tip rollers for easy pallet entry / exit

Rising forks

minimum height: 85mm
maximum height: 200mm

Durable chassis

is constructed from powder-coated heavy-gauge steel.

2 years warranty

guaranteed for peace of mind

Ergonomic handle

is designed for comfortable use for hands of all sizes and has a tough coating for long-lasting performance.

Control lever

has three operating positions; raise, lower and neutral.

Foot pedal release valve

Integrated ACBF* pump

has heavy-duty construction for durability and features overload protection
* Only on 540 x 1150



Characteristics		Cat Lift Trucks	Cat Lift Trucks	Cat Lift Trucks	Cat Lift Trucks	Cat Lift Trucks	Cat Lift Trucks	Cat Lift Trucks	Cat Lift Trucks	
		CV25MNTN	CV25MNSN	CV25MPSP	CV25MRTP	CV25MPPT	CV25IPTP	CV25IRTP	CV30MPTP	
1.1	Manufacturer	Pedestrian	Pedestrian	Pedestrian	Pedestrian	Pedestrian	Pedestrian	Pedestrian	Pedestrian	
1.2	Manufacturer's model designation	2500	2500	2500	2500	2500	2500	2500	3000	
1.4	Operator type	600	600	600	600	600	550	550	600	
1.5	Load capacity	Q	(kg)	45	45	45	45	45	43	
1.6	Load centre distance	c	(mm)	1180	1180	1180	1180	1036	1036	
1.8	Load wheel axle to fork face (forks lowered)	x	(mm)							
1.9	Wheelbase	y	(mm)							
2.0 Weight										
2.1	Truck weight without load, with maximum battery weight	kg	69	68	71	71	72	75	74	68
3.0 Wheels, Drive Train										
3.1	Tyres: PT = Power Thane, Vul = Vulkollan, P = Polyurethane, N = Nylon, R = Rubber drive / load side	NTN	NSN	PSP	RTP	PTP	PTP	RTP	PTP	
3.2	Tyre dimensions, drive side	(mm)	200	200	200	200	180	180	200	
3.3	Tyre dimensions, load side	(mm)	80	80	80	80	80	80	80	
3.4	Castor wheel dimensions (diameter x width)	(mm)	2/4	2/2	2/2	2/4	2/4	2/4	2/4	
3.6	Track width (centre of tyres), drive side	b10 (mm)	120	120	120	120	120	120	120	
3.7	Track width (centre of tyres), load side	b11 (mm)	380	380	380	380	380	525	525	380
4.0 Dimensions										
4.4	Lift height	h3 (mm)	115	115	115	115	115	115	115	
4.9	Height of tiller arm / steering console (min/max)	h14 (mm)	680/1240	680/1240	680/1240	680/1240	680/1240	550/1220	550/1220	680/1240
4.15	Fork height, fully lowered	h13 (mm)	85	85	85	85	85	85	85	
4.19	Overall length	l1 (mm)	1545	1545	1545	1545	1545	1405	1405	1545
4.20	Length to fork face	l2 (mm)	1150	1150	1150	1150	1150	1000	1000	1150
4.21	Overall width	b1/b2 (mm)	540	540	540	540	540	685	685	540
4.22	Fork dimensions (thickness, width, length)	s / e / l (mm)	50, 160 & 1150	50, 160 & 1150	50, 160 & 1150	50, 160 & 1150	50, 160 & 1150	50, 160 & 1000	50, 160 & 1000	50, 160 & 1150
4.25	Outside width over forks (minimum / maximum)	b5 (mm)	540	540	540	540	540	685	685	540
4.32	Ground clearance at centre of wheelbase, (forks lowered)	m2 (mm)	85	85	85	85	85	85	85	85
4.33b	Working aisle width (Ast3) with 1000 x 1200 mm pallets, load crosswise	Ast3 (mm)	2350	2350	2350	2350	2350	2200	2200	2350
4.34b	Working aisle width (Ast3) with 800 x 1200 mm pallets, load lengthwise	Ast3 (mm)	N/A	N/A	N/A	N/A	N/A	N/A	N/A	N/A
4.35	Turning radius	Wa (mm)	1380	1380	1380	1380	1380	1225	1225	1380

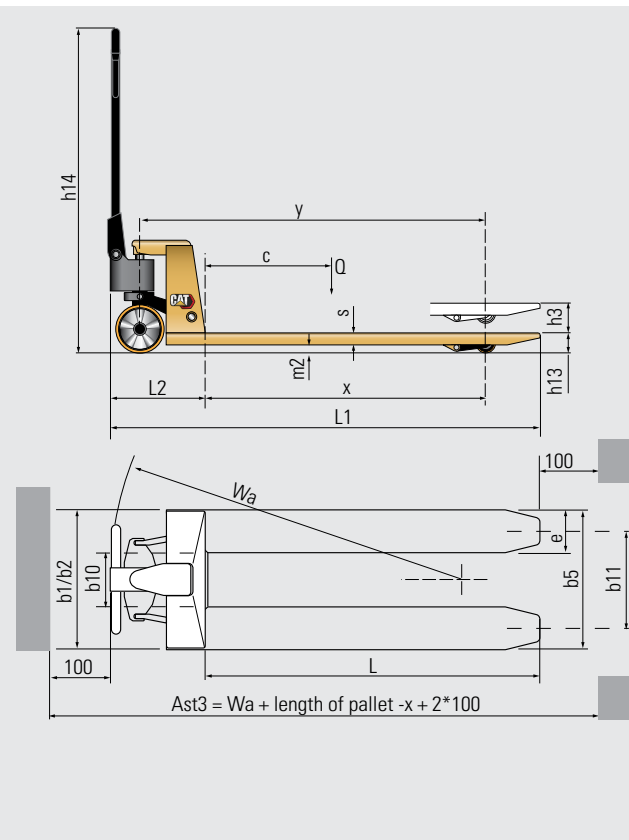

MODEL	FORK DIMENSIONS WxL (mm)	LOAD WHEELS (80mm)	DRIVE WHEEL (200mm*)
CV25MNTN	540 x 1150	4 x (Tandem) Nylon	2 x Nylon*
CV25MNSN		2 x (Single) Nylon	2 x Nylon*
CV25MPSP		2 x (Single) Polyurethane	2 x Polyurethane*
CV25MRTP		4 x (Tandem) Polyurethane	2 x Rubber*
CV25MPPT		4 x (Tandem) Polyurethane	2 x Polyurethane*
CV30MPTP		4 x (Tandem) Polyurethane	2 x Polyurethane*
CV25IPTP (BF pump)	685 x 1000	4 x (Tandem) Polyurethane	2 x Polyurethane (180mm)
CV25IRTP (BF pump)	685 x 1000	4 x (Tandem) Polyurethane	2 x Rubber (180mm)

*Other configurations available on request.

info@catliftruck.com | www.catliftruck.com

(04/26) © 2026 Logisnext Europe B.V. All rights reserved. CAT, CATERPILLAR, LET'S DO THE WORK, and their respective logos "Caterpillar Corporate Yellow", the "Power Edge" and Cat "Modern Hex" trade dress as well as corporate and product identity used herein are trademarks of Caterpillar used under license and may not be used without permission from Caterpillar. Specifications are indicative and may vary depending on operating conditions. Failure to assess all factors may result in performance deviations. All relevant sales support materials and technical expertise of the official distributor must be considered when identifying the best product/solution. Options and technical details may change without notice. Full legal notice and up-to-date product information: www.catliftruck.com.

