



DEPENDABLE PRODUCTIVITY

NSP10N2
NSP12N2C
NSP12N2
NSP12N2R
NSP12N2I
NSP12N2IR
NSP14N2
NSP14N2R
NSP14N2I
NSP14N2IR
NSP16N2
NSP16N2R
NSP16N2I
NSP16N2IR
NSP16N2S
NSP16N2SR

SPECIFICATIONS

PEDESTRIAN AND FOLDING PLATFORM STACKER TRUCKS 24V, 1.0 - 1.6 TONNES



YOUR PERFECT SHORT SHUTTLE PARTNER

THIS RANGE OF STACKERS, INCORPORATING ALL THE LATEST TECHNOLOGY, IS DESIGNED FOR SHORT SHUTTLE APPLICATIONS AND STACKING UP TO 5.4 METRES. WITH A WIDE CHOICE OF PEDESTRIAN AND FOLD-DOWN PLATFORM MODELS, YOU WILL FIND A RELIABLE AND PRODUCTIVE WORKHORSE FOR ANY WAREHOUSE.



Energy-saving programmable drive options, robust construction and high resistance to water and dirt reduce running costs and boost productivity. Maintenance needs are minimised by an integrated drive and lift system, with fewer components, and quick access to all major truck parts.



Smooth and precise control characteristics and a comfortable operating position, with a user-friendly tiller arm and excellent visibility through the mast, ensure a satisfying user experience. Height-adjustable castor wheels* and high-strength masts help to maximise stability.



Models with a small fold-down platform are available at 1.2*, 1.4 and 1.6 tonne capacities to take the legwork out of longer distances.



A new compact pedestrian stacker, the 1.2 tonne NSP12N2C, is now available. This powerful but space-saving model is ideal for filling store shelves, stacking, order picking and short internal transport work in, for example, warehouses, supermarkets and production areas.

*Excluding the NSP12N2C.

LOWER COST OF OWNERSHIP

- Latest AC technology keeps energy consumption and maintenance costs to bare minimum.
- Sturdy chassis construction and endurance-tested forks provide enhanced robustness and reliability even in the toughest conditions.
- Closed chassis and waterproof electrics resist moisture, dirt and corrosion - increasing uptime, cutting maintenance costs and prolonging truck life*.
- Easy access to critical truck components allows faster fault diagnosis and speedier maintenance, squeezing downtime still further.
- Integrated drive and lift system features fewer components than previous models, reducing scope for breakdown.
- Closed compartment with steel cover protects battery against impact, postponing costly battery replacement.
- Standard battery size allows interchangeability with other brands.

UNMATCHED PRODUCTIVITY

- AC motor results in very precise drive control, making life easier for truck operators.
- Ergonomic tiller arm helps keep operators fresh with comfortable, easy-to-use controls.
- Excellent drive and traction characteristics suit intensive work over short and medium distances.
- Advanced programmable controller lets users prioritise between faster performance and smoother handling with lower energy consumption, prolonging shift life.
- Tapered fork tips make for accurate and effortless pallet entry, speeding up handling cycles and preventing pallet or load damage.
- Truck can be driven with tiller arm in vertical position in ultra-low-speed 'tortoise' mode to maximise manoeuvrability in tight spaces.
- Narrower truck body makes handling operations in confined areas much easier.
- The compact NSP12N2C model is the narrowest and lightest stacker (at 660 mm and 775 kg including maximum battery) and like the NSP10-16N2/N2I/N2S models, it has an offset tiller arm so the operator can walk alongside.
- N2R models feature fold-down driver platform that prevents operator fatigue over longer distances.
- N2R models' folding platform stays down when lowered, saving time when operators go to remount.
- N2I initial lift models let operator raise mast and forks, increasing ground clearance to protect truck and load when working on ramps.
- N2S straddle models allow wider loads and bottom-boarded pallets to be handled with ease.

SAFETY AND ERGONOMICS

- Latest tiller arm design provides comfortable operating position.
- High-strength masts reduce load movement to a minimum.
- Slim mast profiles and careful hydraulic hose arrangements make for excellent forward visibility.
- Super-quiet oil-filled transmission helps keep noise levels low.
- Height-adjustable castor wheel eliminates play and raises load stability*.
- Large lift and lower levers allow easy, one-handed control, even with gloves.
- NSP12N2C has speed regulated lifting and a proportional valve for lowering in order to provide smooth and safe handling.

*Excluding the NSP12N2C.



STANDARD EQUIPMENT AND OPTIONS

	NSP10N2	NSP12N2C	NSP12N2(I)	NSP14N2(I)	NSP16N2(I)	NSP12N2(I)R	NSP14N2(I)R	NSP16N2(I)R	NSP16N2S	NSP16N2SR
GENERAL										
LED discharge indicator, no hour meter	●	–	●	●	●	●	●	●	●	●
Multifunctional display, including hour meter	○	○	○	○	○	○	○	○	○	○
Micro-computer incl. hour meter and battery indicator	–	●	–	–	–	–	–	–	–	–
PIN code login 99 codes	–	●	–	–	–	–	–	–	–	–
PIN code login 4 codes	○	–	○	○	○	○	○	○	○	○
Offset tiller arm	–	●	–	–	–	–	–	–	–	–
Chill store design, down to -10°C, with rust-protected axles	–	●	–	–	–	–	–	–	–	–
Speed regulated lifting and proportional valve for lowering, controlled by rocker switch on tiller head	–	●	–	–	–	–	–	–	–	–
Electric on/off valve for lifting and lowering, controlled by rocker switch on tiller head	●	–	●	●	●	●	●	●	●	●
Polyurethane drive wheel	●	●	●	●	●	●	●	●	●	●
Polyurethane drive wheel or rubber	–	●	–	–	–	–	–	–	–	–
Initial lift	–	–	–(●)	–(●)	–(●)	–(●)	–(●)	–(●)	–	–
Single load wheels polyurethane	●	●	●	–	–	–	–	–	–	–
Tandem load wheels polyurethane	○	○	○	●	●	●	●	●	●	●
Adjustable width between straddle load legs; 900mm - 1300mm	–	–	–	–	–	–	–	–	●	●
Sideways battery change (250Ah battery only)	–	–	○	○	○	○	○	○	○	○
Li-ion batteries	–	○	–	–	–	–	–	–	–	–
ENVIRONMENT										
Cold store design, 0°C to -35°C (0°C to -30°C, NSP12N2C)	○	○	○	○	○	○	○	○	○	○
DRIVE AND LIFT CONTROLS										
Tiller up drive	○	○	○	○	○	○	○	○	○	○
WHEEL OPTIONS										
Polyurethane traction and load wheels	●	●	●	●	●	●	●	●	●	●
Power friction traction wheel	○	○	○	○	○	○	○	○	○	○
Non-marking drive wheel	–	○	–	–	–	–	–	–	–	–
Anti-static drive wheel	–	○	–	–	–	–	–	–	–	–
OTHER OPTIONS										
Speed reduction 0,5km/h above 1000mm lift, duplex and triplex masts without free lift	–	–	○	○	○	○	○	○	○	○
Speed reduction 0,5km/h above free lift, duplex and triplex masts with free lift	–	–	○	○	○	○	○	○	○	○
Inbuilt charger, 30A	○	–	○	○	○	○	○	○	○	○
Rubber foot protection	–	–	–	–	–	–	–	–	–	–
Diselectric band	–	○	–	–	–	–	–	–	–	–
Key switch	●	●	●	●	●	●	●	●	●	●
Piezo buzzer instead of standard horn	–	○	–	–	–	–	–	–	–	–
Special RAL colour	○	○	○	○	○	○	○	○	○	○
Load backrest	○	○	○	○	○	○	○	○	○	○
Accessory rack	○	–	○	○	○	○	○	○	○	○
List bracket, A4 size	○	–	○	○	○	○	○	○	○	○
Multi function display	–	○	–	–	–	–	–	–	–	–
Battery creep	–	○	–	–	–	–	–	–	–	–
Battery level audible warning	–	○	–	–	–	–	–	–	–	–
Service alarm	–	○	–	–	–	–	–	–	–	–
Automatic log off	–	○	–	–	–	–	–	–	–	–
Revert to low speed at log off	–	○	–	–	–	–	–	–	–	–

● Standard ○ Option

Characteristics		
1.1	Manufacturer	
1.2	Manufacturer's model designation	
1.3	Power source	
1.4	Operator type	
1.5	Load capacity	Q (kg)
1.6	Load centre distance	c (mm)
1.8	Load wheel axle to fork face (forks lowered)	x (mm)
1.9	Wheelbase	y (mm)
Weight		
2.1b	Truck weight without load, with maximum battery weight	kg
2.2	Axle loadings with nominal load & maximum battery weight, drive / load side	kg
2.3	Axle loadings without load & with maximum battery weight, drive / load side	kg
Wheels, Drive Train		
3.1	Tyres: PT = Power Thane, Vul = Vulkollan, P = Polyurethane, N = Nylon, R = Rubber drive / load side	Vul / Vul
3.2	Tyre dimensions, drive side	(mm)
3.3	Tyre dimensions, load side	(mm)
3.4	Castor wheel dimensions (diameter x width)	(mm)
3.5	Number of wheels, load / drive side (x = driven)	1 + 1x / 2
3.6	Track width (centre of tyres), drive side	b10 (mm)
3.7	Track width (centre of tyres), load side	b11 (mm)
Dimensions		
4.2b	Height	h1 (mm)
4.3	Free lift	h2 (mm)
4.4	Lift height	h3 (mm)
4.5	Height with mast extended	h4 (mm)
4.6	Initial lift	h5 (mm)
4.9	Height of tiller arm / steering console (min/max)	h14 (mm)
4.15	Fork height, fully lowered	h13 (mm)
4.19	Overall length	l1 (mm)
4.20	Length to fork face	l2 (mm)
4.21	Overall width	b1/b2 (mm)
4.22	Fork dimensions (thickness, width, length)	s / e / l (mm)
4.24	Fork carriage width	b3 (mm)
4.25	Outside width over forks (minimum / maximum)	b5 (mm)
4.26	Inner width of support legs	b4 (mm)
4.32	Ground clearance at centre of wheelbase, (forks lowered)	m2 (mm)
4.33c	Working aisle width (Ast) with 1000 x 1200 mm pallets, load crosswise, platform up/down	Ast (mm)
4.33d	Working aisle width (Ast3) with 1000 x 1200 mm pallets, load crosswise, platform up/down	Ast3 (mm)
4.34a	Working aisle width (Ast) with 800 x 1200 mm pallets, load lengthwise	Ast (mm)
4.34b	Working aisle width (Ast3) with 800 x 1200 mm pallets, load lengthwise	Ast3 (mm)
4.34c	Working aisle width (Ast) with 800 x 1200 mm pallets, load lengthwise, platform up/down	Ast (mm)
4.34d	Working aisle width (Ast3) with 800 x 1200 mm pallets, load lengthwise, platform up/down	Ast3 (mm)
4.35	Turning radius	Wa (mm)
Performance		
5.1	Travel speed, with / without load	km / h
5.2	Lifting speed, with / without load	m / s
5.3	Lowering speed, with / without load	m / s
5.7	Gradeability, with / without load	%
5.8	Maximum gradeability with / without load	%
5.9	Acceleration time (10 metres) with / without load	s
5.10	Service brakes (mechanical / hydraulic / electric / pneumatic)	
Electric motors		
6.1	Drive motor capacity (60 min. short duty)	kW
6.2	Lift motor output at 15% duty factor	kW
6.3	Battery to DIN	no
6.4	Battery voltage/capacity at 5-hour discharge	V / Ah
6.5	Battery weight	kg
Miscellaneous		
8.1	Type of drive control	
10.7	Level of noise at the ear level of the driver according to EN 12 053:2001 and EN ISO 4871 in work LpAZ	dB (A)
10.7.1	Level of noise at the ear level of the driver according to EN 12 053:2001 and EN ISO 4871, drive/lift/idle LpAZ	dB (A)
10.7.2	Whole-body vibration (EN 13 059:2002)	
10.7.3	Hand-arm vibration (EN 13 059:2002)	

Cat Lift Trucks
NSP12N2C
 Battery
 Pedestrian

Vul / Vul
 230 x 70
 85 x 99
 140 x 60
 1 + 1x / 2
 382
 355

1400 / 1550
 -
 1700 / 2000
 2145 / 2445
 -
 913 / 1368
 90
 1877
 677
 660
 65 / 185 / 1200

85 / 185 / 1200
 b3 (mm)
 b5 (mm)
 b4 (mm)
 m2 (mm)
 Ast (mm)
 Ast3 (mm)
 Ast (mm)
 Ast3 (mm)
 Ast (mm)
 Ast3 (mm)
 1835

5.7 / 6
 0.10 / 0.20
 0.11 / 0.12
 7 / 19
 %
 7.60 / 6.76
 Electric

1.3
 2.35
 no
 24 / 150-230
 140 - 215

Stepless
 74.6 +/- 0.7

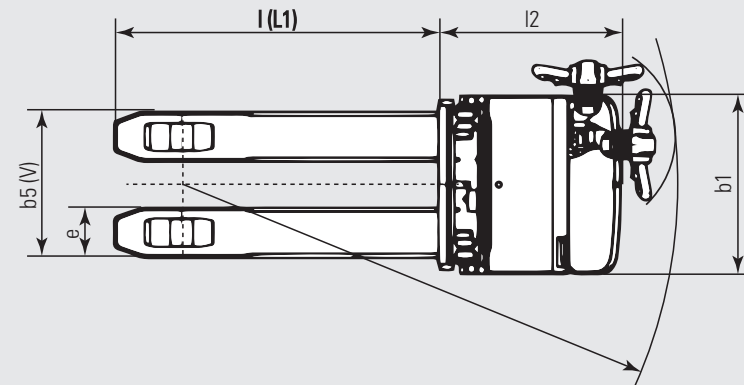
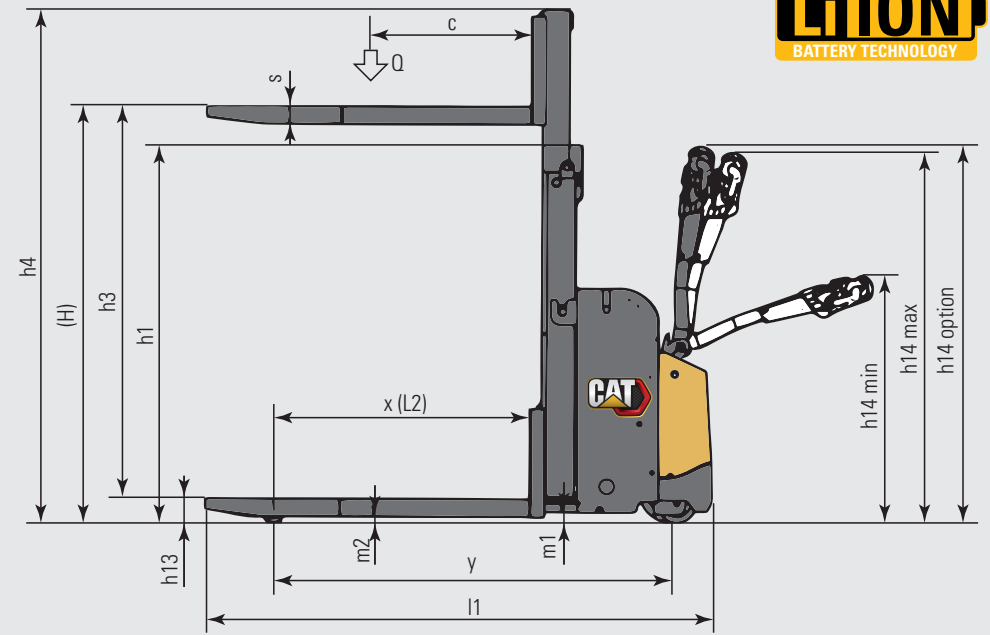

- Ast = Working aisle width
- Ast3 = Working aisle width (b12 < 1000mm)
- Ast = $Wa + \sqrt{(l6 - x)^2 + (b12 / 2)^2} + a$
- Ast3 = $Wa + l6 - x + a$
- Wa = Turning radius
- l6 = Pallet length (800 or 1000mm)
- x = Load wheel axle to fork face
- b12 = Pallet width (1200 mm)
- a = Safety clearance = 2 x 100mm

Characteristics		
1.1	Manufacturer	
1.2	Manufacturer's model designation	
1.3	Power source	
1.4	Operator type	
1.5	Load capacity	Q (kg)
1.6	Load centre distance	c (mm)
1.8	Load wheel axle to fork face (forks lowered)	x (mm)
1.9	Wheelbase	y (mm)
Weight		
2.1b	Truck weight without load, with maximum battery weight	kg
2.2	Axle loadings with nominal load & maximum battery weight, drive / load side	kg
2.3	Axle loadings without load & with maximum battery weight, drive / load side	kg
Wheels, Drive Train		
3.1	Tyres: PT = Power Thane, Vul = Vulkollan, P = Polyurethane, N = Nylon, R = Rubber drive / load side	
3.2	Tyre dimensions, drive side	(mm)
3.3	Tyre dimensions, load side	(mm)
3.4	Castor wheel dimensions (diameter x width)	(mm)
3.5	Number of wheels, load / drive side (x = driven)	
3.6	Track width (centre of tyres), drive side	b10 (mm)
3.7	Track width (centre of tyres), load side	b11 (mm)
Dimensions		
4.2b	Height	h1 (mm)
4.3	Free lift	h2 (mm)
4.4	Lift height	h3 (mm)
4.5	Height with mast extended	h4 (mm)
4.6	Initial lift	h5 (mm)
4.9	Height of tiller arm / steering console (min/max)	h14 (mm)
4.15	Fork height, fully lowered	h13 (mm)
4.19	Overall length	l1 (mm)
4.20	Length to fork face	l2 (mm)
4.21	Overall width	b1/b2 (mm)
4.22	Fork dimensions (thickness, width, length)	s / e / l (mm)
4.24	Fork carriage width	b3 (mm)
4.25	Outside width over forks (minimum / maximum)	b5 (mm)
4.26	Inner width of support legs	b4 (mm)
4.32	Ground clearance at centre of wheelbase, (forks lowered)	m2 (mm)
4.33c	Working aisle width (Ast) with 1000 x 1200 mm pallets, load crosswise, platform up/down	Ast (mm)
4.33d	Working aisle width (Ast3) with 1000 x 1200 mm pallets, load crosswise, platform up/down	Ast3 (mm)
4.34a	Working aisle width (Ast) with 800 x 1200 mm pallets, load lengthwise	Ast (mm)
4.34b	Working aisle width (Ast3) with 800 x 1200 mm pallets, load lengthwise	Ast3 (mm)
4.34c	Working aisle width (Ast) with 800 x 1200 mm pallets, load lengthwise, platform up/down	Ast (mm)
4.34d	Working aisle width (Ast3) with 800 x 1200 mm pallets, load lengthwise, platform up/down	Ast3 (mm)
4.35	Turning radius	Wa (mm)
Performance		
5.1	Travel speed, with / without load	km / h
5.2	Lifting speed, with / without load	m / s
5.3	Lowering speed, with / without load	m / s
5.7	Gradeability, with / without load	%
5.8	Maximum gradeability with / without load	%
5.9	Acceleration time (10 metres) with / without load	s
5.10	Service brakes (mechanical / hydraulic / electric / pneumatic)	
Electric motors		
6.1	Drive motor capacity (60 min. short duty)	kW
6.2	Lift motor output at 15% duty factor	kW
6.3	Battery to DIN	
6.4	Battery voltage/capacity at 5-hour discharge	V / Ah
6.5	Battery weight	kg
Miscellaneous		
8.1	Type of drive control	
10.7	Level of noise at the ear level of the driver according to EN 12 053:2001 and EN ISO 4871 in work LpAZ	dB (A)
10.7.1	Level of noise at the ear level of the driver according to EN 12 053:2001 and EN ISO 4871, drive/lift/idle LpAZ	dB (A)
10.7.2	Whole-body vibration (EN 13 059:2002)	
10.7.3	Hand-arm vibration (EN 13 059:2002)	

Cat Lift Trucks	Cat Lift Trucks	Cat Lift Trucks	Cat Lift Trucks
NSP10N2	NSP12N2	NSP14N2	NSP16N2
Battery	Battery	Battery	Battery
Pedestrian	Pedestrian	Pedestrian	Pedestrian
1000	1200	1400	1600
600	600	600	600
625	625	625	625
1141	1205	1205	1205
820	1205	1220	1225
740 / 1080	830 / 1575	835 / 1785	835 / 1990
605 / 215	820 / 385	825 / 395	825 / 400
Vul / Vul	Vul / Vul	Vul / Vul	Vul / Vul
230 x 70	230 x 70	230 x 70	230 x 70
85 x 90	85 x 90	85 x 75	85 x 75
125 x 60	125 x 60	125 x 60	125 x 60
1 + 1 x / 2	1 + 1 x / 2	1 + 1 x / 4	1 + 1 x / 4
517	517	517	517
385	385	385	385
see tables	see tables	see tables	see tables
see tables	see tables	see tables	see tables
see tables	see tables	see tables	see tables
see tables	see tables	see tables	see tables
-	-	-	-
1050 / 1372	1050 / 1372	1050 / 1372	1050 / 1372
90	90	90	90
1836	1900	1900	1900
686	750	750	750
800	800	800	800
56 / 186 / 1150	56 / 186 / 1150	56 / 186 / 1150	56 / 186 / 1150
752	752	752	752
570	570	570	570
-	-	-	-
20	20	20	20
2291	2355	2355	2355
1958	2022	2022	2022
Ast (mm)			
Ast3 (mm)			
2283	2347	2347	2347
2158	2222	2222	2222
1383	1447	1447	1447
6.0 / 6.0	6.0 / 6.0	6.0 / 6.0	6.0 / 6.0
0.12 / 0.26	0.12 / 0.26	0.12 / 0.26	0.14 / 0.27
0.35 / 0.40	0.35 / 0.40	0.35 / 0.40	0.35 / 0.40
%			
8 / 15	8 / 15	8 / 15	8 / 15
Electric	Electric	Electric	Electric
1.0	1.0	1.0	1.0
2.2	2.2	2.2	3.2
24 / 150	24 / 150-250	24 / 250	24 / 250 - 375
151	151 - 212	212	212 - 294
Stepless	Stepless	Stepless	Stepless
60 / 60 / 41	60 / 60 / 41	60 / 60 / 41	70 / 72 / 41
-	-	-	-
< 2.5	< 2.5	< 2.5	< 2.5

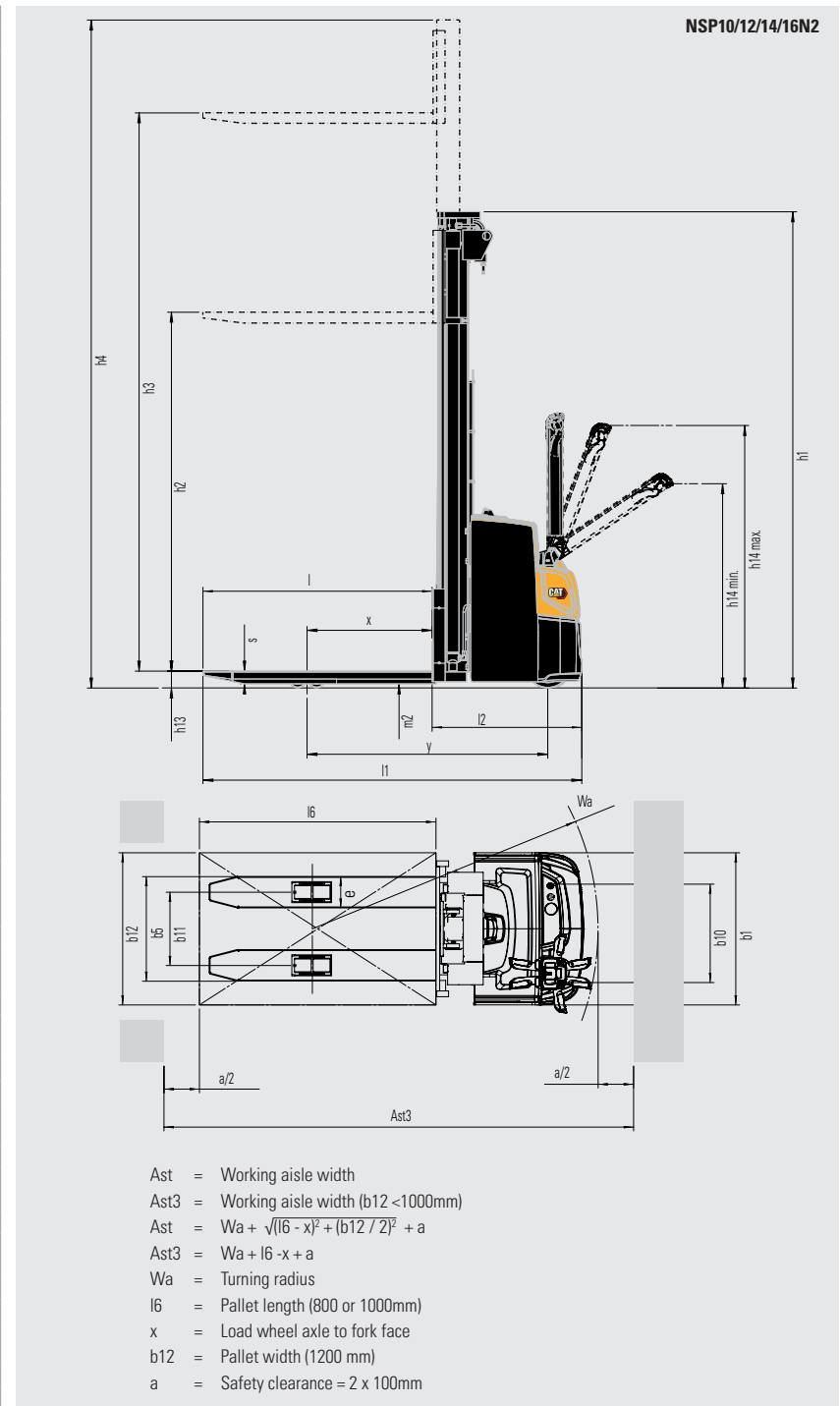

Characteristics		
1.1	Manufacturer	
1.2	Manufacturer's model designation	
1.3	Power source	
1.4	Operator type	
1.5	Load capacity	Q (kg)
1.6	Load centre distance	c (mm)
1.8	Load wheel axle to fork face (forks lowered)	x (mm)
1.9	Wheelbase	y (mm)
Weight		
2.1b	Truck weight without load, with maximum battery weight	kg
2.2	Axle loadings with nominal load & maximum battery weight, drive / load side	kg
2.3	Axle loadings without load & with maximum battery weight, drive / load side	kg
Wheels, Drive Train		
3.1	Tyres: PT = Power Thane, Vul = Vulkollan, P = Polyurethane, N = Nylon, R = Rubber drive / load side	
3.2	Tyre dimensions, drive side	(mm)
3.3	Tyre dimensions, load side	(mm)
3.4	Castor wheel dimensions (diameter x width)	(mm)
3.5	Number of wheels, load / drive side (x = driven)	
3.6	Track width (centre of tyres), drive side	b10 (mm)
3.7	Track width (centre of tyres), load side	b11 (mm)
Dimensions		
4.2b	Height	h1 (mm)
4.3	Free lift	h2 (mm)
4.4	Lift height	h3 (mm)
4.5	Height with mast extended	h4 (mm)
4.6	Initial lift	h5 (mm)
4.9	Height of tiller arm / steering console (min/max)	h14 (mm)
4.15	Fork height, fully lowered	h13 (mm)
4.19	Overall length	l1 (mm)
4.20	Length to fork face	l2 (mm)
4.21	Overall width	b1/b2 (mm)
4.22	Fork dimensions (thickness, width, length)	s / e / l (mm)
4.24	Fork carriage width	b3 (mm)
4.25	Outside width over forks (minimum / maximum)	b5 (mm)
4.26	Inner width of support legs	b4 (mm)
4.32	Ground clearance at centre of wheelbase, (forks lowered)	m2 (mm)
4.33c	Working aisle width (Ast) with 1000 x 1200 mm pallets, load crosswise, platform up/down	Ast (mm)
4.33d	Working aisle width (Ast3) with 1000 x 1200 mm pallets, load crosswise, platform up/down	Ast3 (mm)
4.34a	Working aisle width (Ast) with 800 x 1200 mm pallets, load lengthwise	Ast (mm)
4.34b	Working aisle width (Ast3) with 800 x 1200 mm pallets, load lengthwise	Ast3 (mm)
4.34c	Working aisle width (Ast) with 800 x 1200 mm pallets, load lengthwise, platform up/down	Ast (mm)
4.34d	Working aisle width (Ast3) with 800 x 1200 mm pallets, load lengthwise, platform up/down	Ast3 (mm)
4.35	Turning radius	Wa (mm)
Performance		
5.1	Travel speed, with / without load	km / h
5.2	Lifting speed, with / without load	m / s
5.3	Lowering speed, with / without load	m / s
5.7	Gradeability, with / without load	%
5.8	Maximum gradeability with / without load	%
5.9	Acceleration time (10 metres) with / without load	s
5.10	Service brakes (mechanical / hydraulic / electric / pneumatic)	
Electric motors		
6.1	Drive motor capacity (60 min. short duty)	kW
6.2	Lift motor output at 15% duty factor	kW
6.3	Battery to DIN	
6.4	Battery voltage/capacity at 5-hour discharge	V / Ah
6.5	Battery weight	kg
Miscellaneous		
8.1	Type of drive control	
10.7	Level of noise at the ear level of the driver according to EN 12 053:2001 and EN ISO 4871 in work LpAZ	dB (A)
10.7.1	Level of noise at the ear level of the driver according to EN 12 053:2001 and EN ISO 4871, drive/lift/idle LpAZ	dB (A)
10.7.2	Whole-body vibration (EN 13 059:2002)	
10.7.3	Hand-arm vibration (EN 13 059:2002)	

Cat Lift Trucks	Cat Lift Trucks	Cat Lift Trucks
NSP12N2I	NSP14N2I	NSP16N2I
Battery	Battery	Battery
Pedestrian	Pedestrian	Pedestrian
1200	1400	1600
600	600	600
925	925	925
1615	1615	1615
1350	1395	1400
1180 / 1370	1240 / 1555	1275 / 1725
955 / 395	970 / 425	970 / 430
Vul / Vul	Vul / Vul	Vul / Vul
230 x 70	230 x 70	230 x 70
85 x 90	85 x 75	85 x 75
125 x 60	125 x 60	125 x 60
1 + 1 x / 2	1 + 1 x / 4	1 + 1 x / 4
517	517	517
385	385	385
see tables	see tables	see tables
see tables	see tables	see tables
see tables	see tables	see tables
see tables	see tables	see tables
115	115	115
1050 / 1372	1050 / 1372	1050 / 1372
90	90	90
2007	2007	2007
857	857	857
800	800	800
56 / 186 / 1150	56 / 186 / 1150	56 / 186 / 1150
752	752	752
570	570	570
-	-	-
20	20	20
2653	2653	2653
2123	2123	2123
Ast (mm)	Ast (mm)	Ast (mm)
2533	2533	2533
2323	2323	2323
1848	1848	1848
6.0 / 6.0	6.0 / 6.0	6.0 / 6.0
0.12 / 0.26	0.12 / 0.26	0.14 / 0.27
0.35 / 0.40	0.35 / 0.40	0.35 / 0.40
%	%	%
8 / 15	8 / 15	8 / 15
Electric	Electric	Electric
1.0	1.0	1.0
2.2	2.2	3.2
24 / 150-250	24 / 250	24 / 250 - 375
151 - 212	212	212 - 294
Stepless	Stepless	Stepless
60 / 60 / 41	60 / 60 / 41	70 / 72 / 41
-	-	-
< 2.5	< 2.5	< 2.5

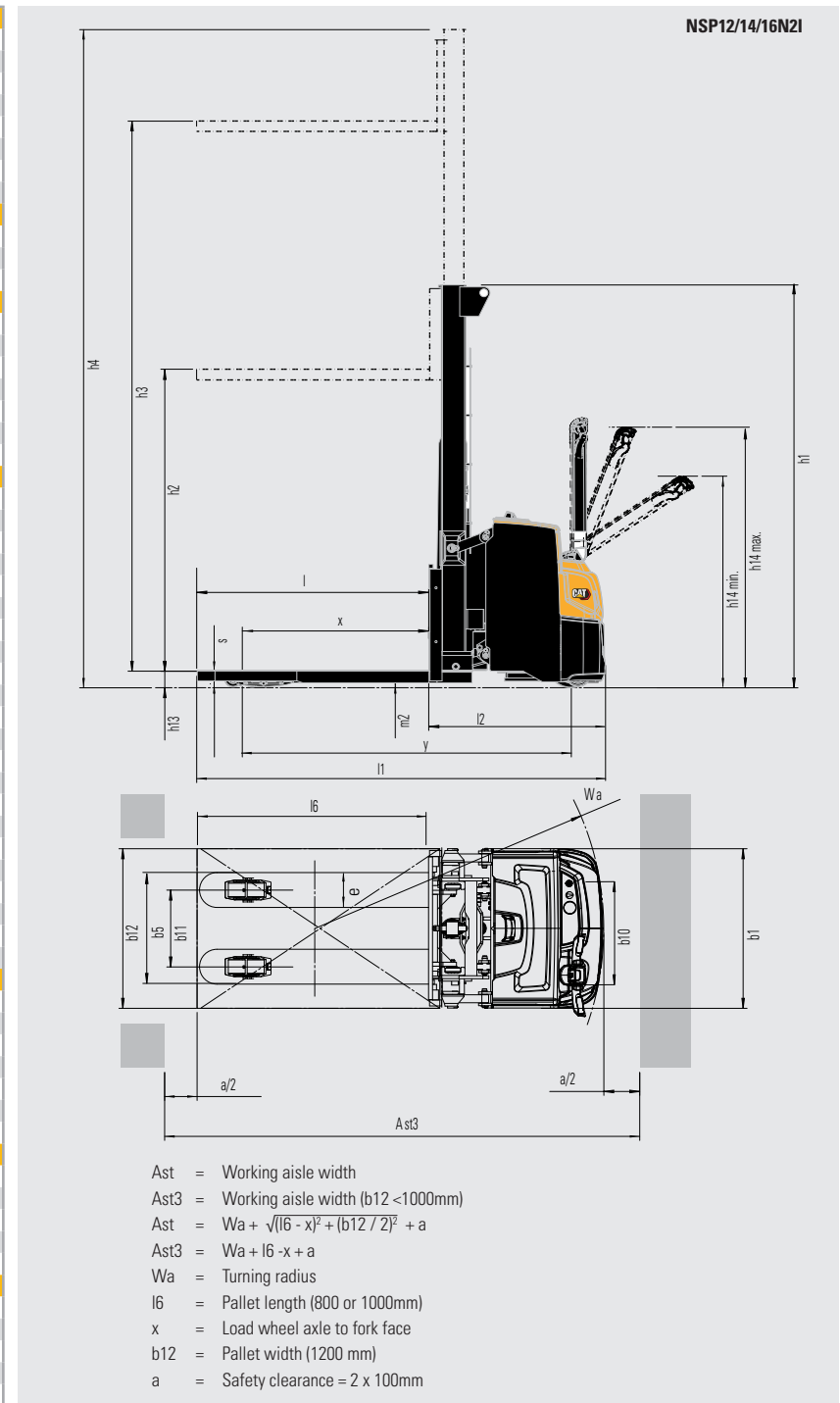

Characteristics			Cat Lift Trucks	Cat Lift Trucks	Cat Lift Trucks
			NSP12N2R	NSP14N2R	NSP16N2R
			Battery	Battery	Battery
			Pedestrian / Stand-on	Pedestrian / Stand-on	Pedestrian / Stand-on
1.1	Manufacturer				
1.2	Manufacturer's model designation				
1.3	Power source				
1.4	Operator type				
1.5	Load capacity	Q (kg)	1200	1400	1600
1.6	Load centre distance	c (mm)	600	600	600
1.8	Load wheel axle to fork face (forks lowered)	x (mm)	625	625	625
1.9	Wheelbase	y (mm)	1205	1205	1205
Weight					
2.1b	Truck weight without load, with maximum battery weight	kg	1245	1260	1265
2.2	Axle loadings with nominal load & maximum battery weight, drive / load side	kg	870 / 1575	875 / 1785	875 / 1990
2.3	Axle loadings without load & with maximum battery weight, drive / load side	kg	860 / 385	865 / 395	865 / 400
Wheels, Drive Train					
3.1	Tyres: PT = Power Thane, Vul = Vulkollan, P = Polyurethane, N = Nylon, R = Rubber drive / load side		Vul / Vul	Vul / Vul	Vul / Vul
3.2	Tyre dimensions, drive side	(mm)	230 x 70	230 x 70	230 x 70
3.3	Tyre dimensions, load side	(mm)	85 x 90	85 x 75	85 x 75
3.4	Castor wheel dimensions (diameter x width)	(mm)	125 x 60	125 x 60	125 x 60
3.5	Number of wheels, load / drive side (x = driven)		1 + 1 x / 2	1 + 1 x / 4	1 + 1 x / 4
3.6	Track width (centre of tyres), drive side	b10 (mm)	517	517	517
3.7	Track width (centre of tyres), load side	b11 (mm)	385	385	385
Dimensions					
4.2b	Height	h1 (mm)	see tables	see tables	see tables
4.3	Free lift	h2 (mm)	see tables	see tables	see tables
4.4	Lift height	h3 (mm)	see tables	see tables	see tables
4.5	Height with mast extended	h4 (mm)	see tables	see tables	see tables
4.6	Initial lift	h5 (mm)	-	-	-
4.9	Height of tiller arm / steering console (min/max)	h14 (mm)	1150 / 1350	1150 / 1350	1150 / 1350
4.15	Fork height, fully lowered	h13 (mm)	90	90	90
4.19	Overall length	l1 (mm)	2020 / 2500	2020 / 2500	2020 / 2500
4.20	Length to fork face	l2 (mm)	870 / 1350	870 / 1350	870 / 1350
4.21	Overall width	b1/b2 (mm)	800	800	800
4.22	Fork dimensions (thickness, width, length)	s / e / l (mm)	56 / 186 / 1150	56 / 186 / 1150	56 / 186 / 1150
4.24	Fork carriage width	b3 (mm)	752	752	752
4.25	Outside width over forks (minimum / maximum)	b5 (mm)	570	570	570
4.26	Inner width of support legs	b4 (mm)	-	-	-
4.32	Ground clearance at centre of wheelbase, (forks lowered)	m2 (mm)	20	20	20
4.33c	Working aisle width (Ast) with 1000 x 1200 mm pallets, load crosswise, platform up/down	Ast (mm)	2475 / 2955	2475 / 2955	2475 / 2955
4.33d	Working aisle width (Ast3) with 1000 x 1200 mm pallets, load crosswise, platform up/down	Ast3 (mm)	2142 / 2622	2142 / 2622	2142 / 2622
4.34a	Working aisle width (Ast) with 800 x 1200 mm pallets, load lengthwise	Ast (mm)			
4.34b	Working aisle width (Ast3) with 800 x 1200 mm pallets, load lengthwise	Ast3 (mm)			
4.34c	Working aisle width (Ast) with 800 x 1200 mm pallets, load lengthwise, platform up/down	Ast (mm)	2467 / 2947	2467 / 2947	2467 / 2947
4.34d	Working aisle width (Ast3) with 800 x 1200 mm pallets, load lengthwise, platform up/down	Ast3 (mm)	2342 / 2822	2342 / 2822	2342 / 2822
4.35	Turning radius	Wa (mm)	1567 / 2047	1567 / 2047	1567 / 2047
Performance					
5.1	Travel speed, with / without load	km / h	6.0 / 6.0	6.0 / 6.0	6.0 / 6.0
5.2	Lifting speed, with / without load	m / s	0.12 / 0.26	0.12 / 0.26	0.14 / 0.27
5.3	Lowering speed, with / without load	m / s	0.35 / 0.40	0.35 / 0.40	0.35 / 0.40
5.7	Gradeability, with / without load	%			
5.8	Maximum gradeability with / without load	%	8 / 15	8 / 15	8 / 15
5.9	Acceleration time (10 metres) with / without load	s			
5.10	Service brakes (mechanical / hydraulic / electric / pneumatic)		Electric	Electric	Electric
Electric motors					
6.1	Drive motor capacity (60 min. short duty)	kW	1.0	1.0	1.0
6.2	Lift motor output at 15% duty factor	kW	2.2	2.2	3.2
6.3	Battery to DIN				
6.4	Battery voltage/capacity at 5-hour discharge	V / Ah	24 / 150 - 250	24 / 250	24 / 250 - 375
6.5	Battery weight	kg	151 - 212	212	212 - 294
Miscellaneous					
8.1	Type of drive control		Stepless	Stepless	Stepless
10.7	Level of noise at the ear level of the driver according to EN 12 053:2001 and EN ISO 4871 in work LpAZ	dB (A)			
10.7.1	Level of noise at the ear level of the driver according to EN 12 053:2001 and EN ISO 4871, drive/lift/idle LpAZ	dB (A)	60 / 60 / 41	60 / 60 / 41	70 / 72 / 41
10.7.2	Whole-body vibration (EN 13 059:2002)		0.8	0.8	0.8
10.7.3	Hand-arm vibration (EN 13 059:2002)		< 2.5	< 2.5	< 2.5

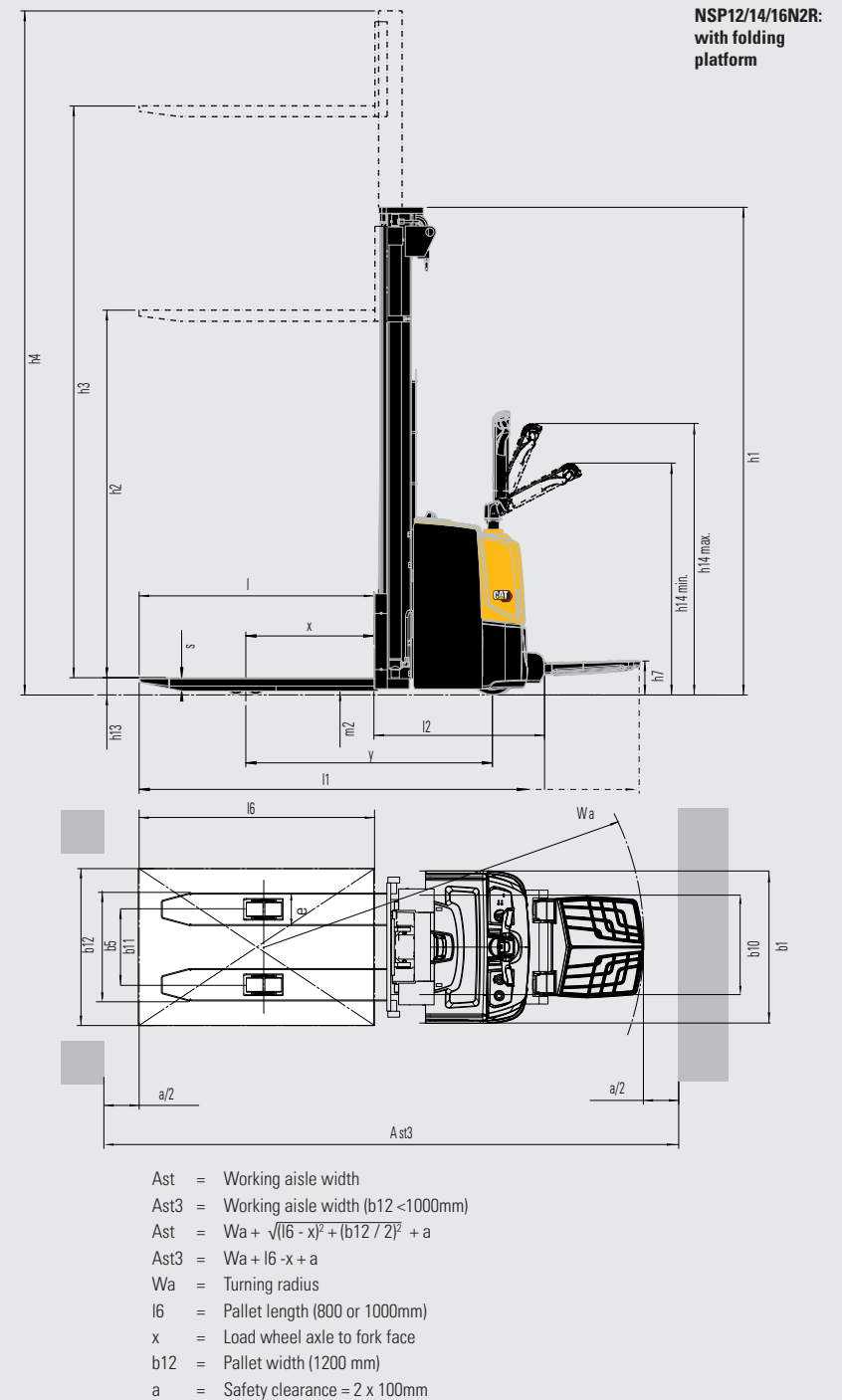

Characteristics			Cat Lift Trucks	Cat Lift Trucks	Cat Lift Trucks
			NSP12N2IR	NSP14N2IR	NSP16N2IR
			Battery	Battery	Battery
			Pedestrian / Stand-on	Pedestrian / Stand-on	Pedestrian / Stand-on
1.1	Manufacturer				
1.2	Manufacturer's model designation				
1.3	Power source				
1.4	Operator type				
1.5	Load capacity	Q (kg)	1200	1400	1600
1.6	Load centre distance	c (mm)	600	600	600
1.8	Load wheel axle to fork face (forks lowered)	x (mm)	925	925	925
1.9	Wheelbase	y (mm)	1615	1615	1615
Weight					
2.1b	Truck weight without load, with maximum battery weight	kg	1390	1435	1440
2.2	Axle loadings with nominal load & maximum battery weight, drive / load side	kg	1220 / 1370	1280 / 1555	1315 / 1725
2.3	Axle loadings without load & with maximum battery weight, drive / load side	kg	995 / 395	1010 / 425	1010 / 430
Wheels, Drive Train					
3.1	Tyres: PT = Power Thane, Vul = Vulkollan, P = Polyurethane, N = Nylon, R = Rubber drive / load side		Vul / Vul	Vul / Vul	Vul / Vul
3.2	Tyre dimensions, drive side	(mm)	230 x 70	230 x 70	230 x 70
3.3	Tyre dimensions, load side	(mm)	85 x 90	85 x 75	85 x 75
3.4	Castor wheel dimensions (diameter x width)	(mm)	125 x 60	125 x 60	125 x 60
3.5	Number of wheels, load / drive side (x = driven)		1 + 1 x / 2	1 + 1 x / 4	1 + 1 x / 4
3.6	Track width (centre of tyres), drive side	b10 (mm)	517	517	517
3.7	Track width (centre of tyres), load side	b11 (mm)	385	385	385
Dimensions					
4.2b	Height	h1 (mm)	see tables	see tables	see tables
4.3	Free lift	h2 (mm)	see tables	see tables	see tables
4.4	Lift height	h3 (mm)	see tables	see tables	see tables
4.5	Height with mast extended	h4 (mm)	see tables	see tables	see tables
4.6	Initial lift	h5 (mm)	115	115	115
4.9	Height of tiller arm / steering console (min/max)	h14 (mm)	1150 / 1350	1150 / 1350	1150 / 1350
4.15	Fork height, fully lowered	h13 (mm)	90	90	90
4.19	Overall length	l1 (mm)	2127 / 2607	2127 / 2607	2127 / 2607
4.20	Length to fork face	l2 (mm)	977 / 1457	977 / 1457	977 / 1457
4.21	Overall width	b1/b2 (mm)	800	800	800
4.22	Fork dimensions (thickness, width, length)	s / e / l (mm)	56 / 186 / 1150	56 / 186 / 1150	56 / 186 / 1150
4.24	Fork carriage width	b3 (mm)	752	752	752
4.25	Outside width over forks (minimum / maximum)	b5 (mm)	570	570	570
4.26	Inner width of support legs	b4 (mm)	-	-	-
4.32	Ground clearance at centre of wheelbase, (forks lowered)	m2 (mm)	20	20	20
4.33c	Working aisle width (Ast) with 1000 x 1200 mm pallets, load crosswise, platform up/down	Ast (mm)	2773 / 3253	2773 / 3253	2773 / 3253
4.33d	Working aisle width (Ast3) with 1000 x 1200 mm pallets, load crosswise, platform up/down	Ast3 (mm)	2243 / 2723	2243 / 2723	2243 / 2723
4.34a	Working aisle width (Ast) with 800 x 1200 mm pallets, load lengthwise	Ast (mm)			
4.34b	Working aisle width (Ast3) with 800 x 1200 mm pallets, load lengthwise	Ast3 (mm)			
4.34c	Working aisle width (Ast) with 800 x 1200 mm pallets, load lengthwise, platform up/down	Ast (mm)	2653 / 3133	2653 / 3133	2653 / 3133
4.34d	Working aisle width (Ast3) with 800 x 1200 mm pallets, load lengthwise, platform up/down	Ast3 (mm)	2443 / 2923	2443 / 2923	2443 / 2923
4.35	Turning radius	Wa (mm)	1968 / 2448	1968 / 2448	1968 / 2448
Performance					
5.1	Travel speed, with / without load	km / h	6.0 / 6.0	6.0 / 6.0	6.0 / 6.0
5.2	Lifting speed, with / without load	m / s	0.12 / 0.26	0.12 / 0.26	0.14 / 0.27
5.3	Lowering speed, with / without load	m / s	0.35 / 0.40	0.35 / 0.40	0.35 / 0.40
5.7	Gradeability, with / without load	%			
5.8	Maximum gradeability with / without load	%	8 / 15	8 / 15	8 / 15
5.9	Acceleration time (10 metres) with / without load	s			
5.10	Service brakes (mechanical / hydraulic / electric / pneumatic)		Electric	Electric	Electric
Electric motors					
6.1	Drive motor capacity (60 min. short duty)	kW	1.0	1.0	1.0
6.2	Lift motor output at 15% duty factor	kW	2.2	2.2	3.2
6.3	Battery to DIN				
6.4	Battery voltage/capacity at 5-hour discharge	V / Ah	24 / 150 - 250	24 / 250	24 / 250 - 375
6.5	Battery weight	kg	151 - 212	212	212 - 294
Miscellaneous					
8.1	Type of drive control		Stepless	Stepless	Stepless
10.7	Level of noise at the ear level of the driver according to EN 12 053:2001 and EN ISO 4871 in work LpAZ	dB (A)			
10.7.1	Level of noise at the ear level of the driver according to EN 12 053:2001 and EN ISO 4871, drive/lift/idle LpAZ	dB (A)	60 / 60 / 41	60 / 60 / 41	70 / 72 / 41
10.7.2	Whole-body vibration (EN 13 059:2002)		0.8	0.8	0.8
10.7.3	Hand-arm vibration (EN 13 059:2002)		< 2.5	< 2.5	< 2.5

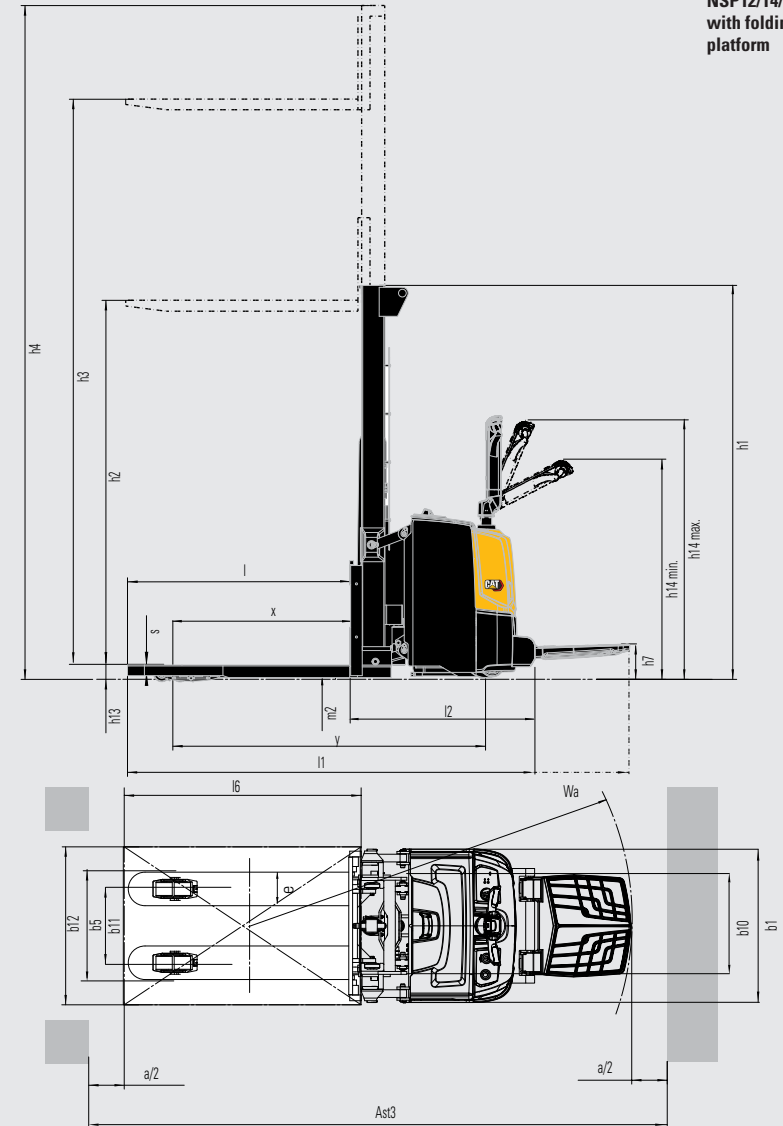

NSP12/14/16N2IR:
with folding platform

- Ast = Working aisle width
- Ast3 = Working aisle width (b12 < 1000mm)
- Ast = $Wa + \sqrt{(l6 - x)^2 + (b12 / 2)^2} + a$
- Ast3 = $Wa + l6 - x + a$
- Wa = Turning radius
- l6 = Pallet length (800 or 1000mm)
- x = Load wheel axle to fork face
- b12 = Pallet width (1200 mm)
- a = Safety clearance = 2 x 100mm

Characteristics			Cat Lift Trucks	Cat Lift Trucks
1.1	Manufacturer		NSP16N2S	NSP16N2SR
1.2	Manufacturer's model designation		Battery	Battery
1.3	Power source		Pedestrian	Pedestrian / Stand-on
1.4	Operator type			
1.5	Load capacity	Q (kg)	1600	1600
1.6	Load centre distance	c (mm)	600	600
1.8	Load wheel axle to fork face (forks lowered)	x (mm)	650	650
1.9	Wheelbase	y (mm)	1295	1295
Weight				
2.1b	Truck weight without load, with maximum battery weight	kg	1397	1437
2.2	Axle loadings with nominal load & maximum battery weight, drive / load side	kg	1941 / 1056	1981 / 1056
2.3	Axle loadings without load & with maximum battery weight, drive / load side	kg	945 / 452	985 / 452
Wheels, Drive Train				
3.1	Tyres: PT = Power Thane, Vul = Vulkollan, P = Polyurethane, N = Nylon, R = Rubber drive / load side		Vul / Vul	Vul / Vul
3.2	Tyre dimensions, drive side	(mm)	230 x 70	230 x 70
3.3	Tyre dimensions, load side	(mm)	85 x 75	85 x 75
3.4	Castor wheel dimensions (diameter x width)	(mm)	125 x 60	125 x 60
3.5	Number of wheels, load / drive side (x = driven)		1 + 1 x / 4	1 + 1 x / 4
3.6	Track width (centre of tyres), drive side	b10 (mm)	517	517
3.7	Track width (centre of tyres), load side	b11 (mm)	1025-1425	1025-1425
Dimensions				
4.2b	Height	h1 (mm)	see tables	see tables
4.3	Free lift	h2 (mm)	see tables	see tables
4.4	Lift height	h3 (mm)	see tables	see tables
4.5	Height with mast extended	h4 (mm)	see tables	see tables
4.6	Initial lift	h5 (mm)	-	-
4.9	Height of tiller arm / steering console (min/max)	h14 (mm)	1050 / 1372	1150 / 1350
4.15	Fork height, fully lowered	h13 (mm)	85	85
4.19	Overall length	l1 (mm)	1967	2087 / 2567
4.20	Length to fork face	l2 (mm)	817	937 / 1417
4.21	Overall width	b1/b2 (mm)	800 / 1140 - 1575	800 / 1140 - 1575
4.22	Fork dimensions (thickness, width, length)	s / e / l (mm)	40 / 100 / 1150	40 / 100 / 1150
4.24	Fork carriage width	b3 (mm)	980	980
4.25	Outside width over forks (minimum / maximum)	b5 (mm)	260-900	260-900
4.26	Inner width of support legs	b4 (mm)	900-1300	900-1300
4.32	Ground clearance at centre of wheelbase, (forks lowered)	m2 (mm)	20	20
4.33c	Working aisle width (Ast) with 1000 x 1200 mm pallets, load crosswise, platform up/down	Ast (mm)	2430	2550 / 3030
4.33d	Working aisle width (Ast3) with 1000 x 1200 mm pallets, load crosswise, platform up/down	Ast3 (mm)	2085	2205 / 2685
4.34a	Working aisle width (Ast) with 800 x 1200 mm pallets, load lengthwise	Ast (mm)		
4.34b	Working aisle width (Ast3) with 800 x 1200 mm pallets, load lengthwise	Ast3 (mm)		
4.34c	Working aisle width (Ast) with 800 x 1200 mm pallets, load lengthwise, platform up/down	Ast (mm)	2415	2535 / 3015
4.34d	Working aisle width (Ast3) with 800 x 1200 mm pallets, load lengthwise, platform up/down	Ast3 (mm)	2285	2405 / 2885
4.35	Turning radius	Wa (mm)	1535	1655 / 2135
Performance				
5.1	Travel speed, with / without load	km / h	6.0 / 6.0	6.0 / 6.0
5.2	Lifting speed, with / without load	m / s	0.14 / 0.27	0.14 / 0.27
5.3	Lowering speed, with / without load	m / s	0.35 / 0.40	0.35 / 0.40
5.7	Gradeability, with / without load	%		
5.8	Maximum gradeability with / without load	%	8 / 15	8 / 15
5.9	Acceleration time (10 metres) with / without load	s		
5.10	Service brakes (mechanical / hydraulic / electric / pneumatic)		Electric	Electric
Electric motors				
6.1	Drive motor capacity (60 min. short duty)	kW	1.0	1.0
6.2	Lift motor output at 15% duty factor	kW	3.2	3.2
6.3	Battery to DIN			
6.4	Battery voltage/capacity at 5-hour discharge	V / Ah	24 / 250 - 375	24 / 250 - 375
6.5	Battery weight	kg	212 - 294	212 - 294
Miscellaneous				
8.1	Type of drive control		Stepless	Stepless
10.7	Level of noise at the ear level of the driver according to EN 12 053:2001 and EN ISO 4871 in work LpAZ	dB (A)		
10.7.1	Level of noise at the ear level of the driver according to EN 12 053:2001 and EN ISO 4871, drive/lift/idle LpAZ	dB (A)	70 / 72 / 41	70 / 72 / 41
10.7.2	Whole-body vibration (EN 13 059:2002)		-	0.8
10.7.3	Hand-arm vibration (EN 13 059:2002)		< 2.5	< 2.5

- Ast = Working aisle width
 Ast3 = Working aisle width (b12 < 1000mm)
 $Ast = Wa + \sqrt{(l6 - x)^2 + (b12 / 2)^2} + a$
 Ast3 = $Wa + l6 - x + a$
 Wa = Turning radius
 l6 = Pallet length (800 or 1000mm)
 x = Load wheel axle to fork face
 b12 = Pallet width (1200 mm)
 a = Safety clearance = 2 x 100mm

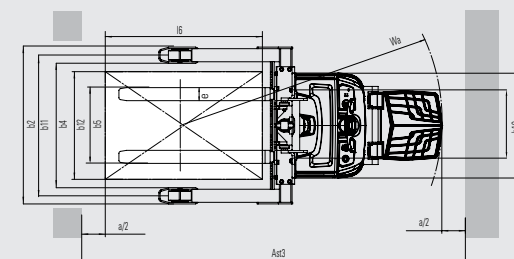
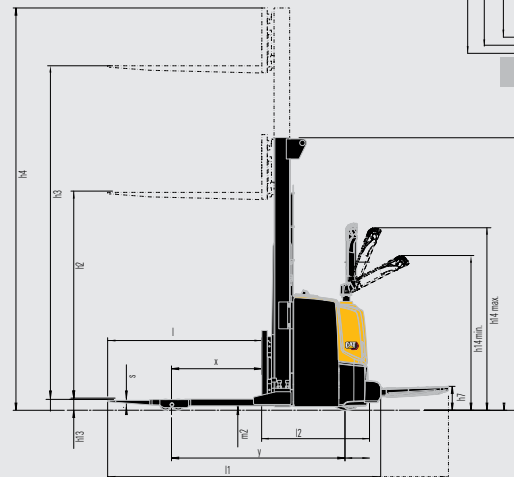
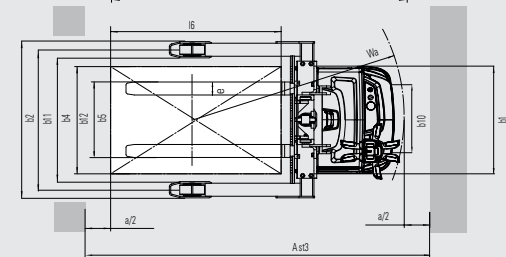
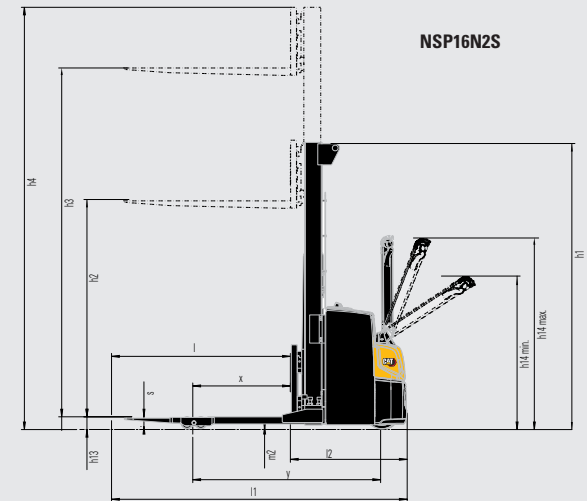

NSP16N2SR:
with folding platform

NSP12N2C			
Mast Type	h3+h13	h1*	h2+h13
	mm	mm	mm
Duplex	1790	1400	NA
Without Free Lift	2090	1550	NA

* h1 closed mast height includes polycarbonate finger protection. Mast height excl. finger protection is 1343mm / 1493mm

NSP10N2				
Mast Type	h3+h13	h1*	h4	h2+h13
	mm	mm	mm	mm
Simplex	1500	1980	1980	1500
Duplex	2500	1775	3000	195
	2900	1975	3400	195
	3300	2175	3800	195

NSP12/14/16N2 / NSP12/14 / 16N2R				
Mast Type	h3+h13	h1*	h4	h2+h13
	mm	mm	mm	mm
Simplex	1500	1950	1950	1500
	2500	1835	3000	200
	2900	2035	3400	200
	3300	2235	3800	200
	3600	2385	4100	200
Duplex Free Lift	4300	2735	4800	200
	2500	1775	2940	1355
	2900	1975	3340	1555
	3300	2235	3800	1755
Triplex	3600	2385	4100	1905
	4300	2735	4800	2255
	4100	1955	4640	
	4300	2020	4840	
Triplex Free Lift	4700	2153	5250	
	5400*	2385	5940	
	4100	1955	4640	1475
	4300	2020	4840	1540
Triplex Free Lift	4700	2153	5250	1673
	5400*	2385	5940	1905

NSP12/14/16N2I / NSP12/14/16N2IR				
Mast Type	h3+h13	h1*	h4	h2+h13
	mm	mm	mm	mm
Simplex	1500	2055	2055	1505
	2500	1940	3105	200
	2900	2140	3505	200
	3300	2340	3905	200
	3600	2490	4205	200
	4300	2840	4905	200
	Duplex Free Lift	2500	1940	3105
2900		2140	3505	1560
3300		2340	3905	1760
3600		2490	4205	1910
Triplex	4300	2840	4905	2260
	4100	2060	4745	
	4300	2125	4945	
	4700	2260	5345	
Triplex Free Lift	5400*	2490	6045	
	4100	2060	4745	1480
	4300	2125	4945	1545
	4700	2260	5345	1673
Triplex Free Lift	5400*	2490	6045	1910

NSP16N2S / NSP16N2SR				
Mast Type	h3+h13	h1*	h4	h2+h13
	mm	mm	mm	mm
Simplex	1500	2030	2030	1500
	2500	1915	3080	195
	2900	2115	3480	195
	3300	2315	3880	195
	3600	2465	4180	195
	4300	2815	4880	195
Duplex Free Lift	2500	1915	3080	1355
	2900	2115	3480	1555
	3300	2315	3880	1755
	3600	2465	4180	1905
Triplex	4300	2815	4880	2255
	4100	2035	4720	
	4300	2100	4920	
	4700	2233	5320	
Triplex Free Lift	5400*	2465	6020	
	4100	2035	4720	1475
	4300	2100	4920	1540
	4700	2233	5320	1753
Triplex Free Lift	5400*	2465	6020	1905

Mast Performance and Capacity

- * = only NSP14-16N2R & NSP14-16N2(I)R
- S = Simplex
- DS = Duplex with clear view mast
- DEV = Duplex with full free lift
- TR = Triplex with clear view mast
- TREV = Triplex with full free lift
- h3+h13 = Lifting height
- h1 = Lowered mast height
- h4 = Raised mast height
- h2+h13 = Free lift



LI-ION BATTERIES

CONSIDER THE BENEFITS OF LI-ION BATTERY TECHNOLOGY ON THE NSP12N2C MODEL



Lithium-ion (Li-ion) battery technology is available in the Cat® electric counterbalance and warehouse truck ranges. While lead-acid batteries remain a popular choice for our customers, and still have much to offer, they present various challenges which Li-ion can overcome.

Perhaps the most noticeable change when switching to Li-ion is the use of opportunity charging. Instead of exchanging batteries between shifts, you can simply plug into a fast charger during short breaks and keep the same battery going 24/7. This, together with other efficiency, environmental and safety benefits, makes Li-ion a very appealing alternative.



LONGER LIFE



HIGHER EFFICIENCY



LONGER RUNTIME

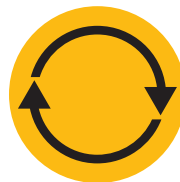

CONSISTENT PERFORMANCE



FASTER CHARGING



NO BATTERY CHANGING



NO DAILY MAINTENANCE



INBUILT PROTECTION

Cat Li-ion advantages over lead-acid

Li-ion is an investment which should be viewed against ongoing savings on energy, equipment, labour and downtime.

- **Longer life** – 3 to 4 times lead-acid lifespan – reduces overall battery investment
- **Higher efficiency** – energy losses during charging and discharging are up to 30% lower, so electricity consumption is reduced
- **Longer runtime** – thanks to more efficient battery performance and use of opportunity charges, which can be given at any time without damaging the battery or shortening its lifespan
- **Consistently high performance** – with a more constant voltage curve – maintains greater truck productivity, even toward the end of a shift
- **Faster charging** – enables full charge in as little as 1 hour with the fastest chargers
- **No battery changing** – fast opportunity charges – 15 minutes for several hours of extra runtime – enable continuous operation with just one battery and minimise the need to buy, store and maintain spares
- **No daily maintenance** – the battery stays on board the truck for charging and there is no need for water top-ups or electrolyte checks
- **No gas** – or acid spills – avoids the space, equipment and running costs of a battery room and ventilation system
- **Inbuilt protection** – intelligent battery management system (BMS) automatically prevents excessive discharge, charge, voltage and temperature, as well as virtually eliminating misuse

Batteries and chargers with different capacities are available. Your dealer will identify the best combination for your needs. You should also ask your dealer about optional 5-year warranties, subject to annual check-ups, which give extra peace of mind.

info@catliftruck.com | www.catliftruck.com

WESC2210(05/22) © 2022 MLE B.V. (registration no. 33274459). All rights reserved. CAT, CATERPILLAR, LET'S DO THE WORK, their respective logos, "Caterpillar Corporate Yellow", the "Power Edge" and Cat "Modern Hex" trade dress as well as corporate and product identity used herein, are trademarks of Caterpillar and may not be used without permission.

NOTE: Performance specifications may vary depending on standard manufacturing tolerances, vehicle condition, types of tyres, floor or surface conditions, applications, or operating environment. Trucks may be shown with non-standard options. Specific performance requirements and locally available configurations should be discussed with your Cat lift trucks Dealer. Cat Lift Trucks follows a policy of continual product improvement. For this reason, some materials, options and specifications could change without notice.



DOWNLOAD BROCHURE



WATCH VIDEOS



DOWNLOAD OUR APP

